

September 17, 2009



Planar Graphs and Planar Posets - III

William T. Trotter
trotter@math.gatech.edu

Planar Multigraphs

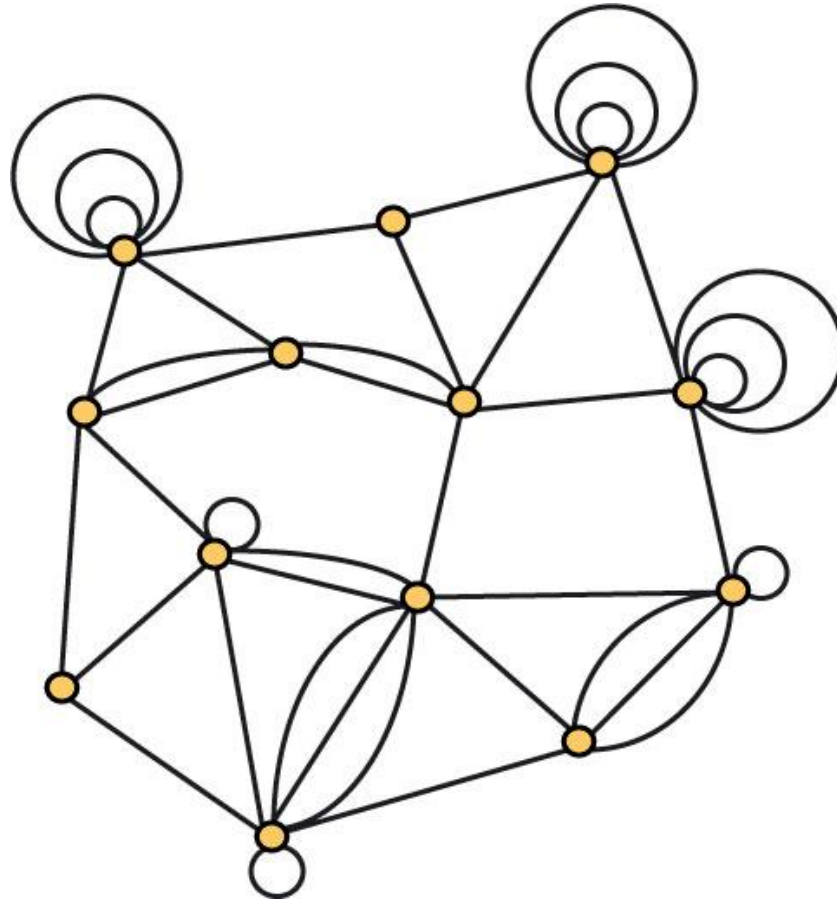

Planar Multigraphs

Theorem (Brightwell and Trotter): Let D be a non-crossing drawing of a planar multigraph G , and let P be the vertex-edge-face poset determined by D . Then $\dim(P) \leq 4$.

Different drawings may determine posets with different dimensions.

Dimension of Planar Posets

Theorem If P has both a 0 and a 1, then P is planar if and only if it is a lattice and has dimension at most 2.

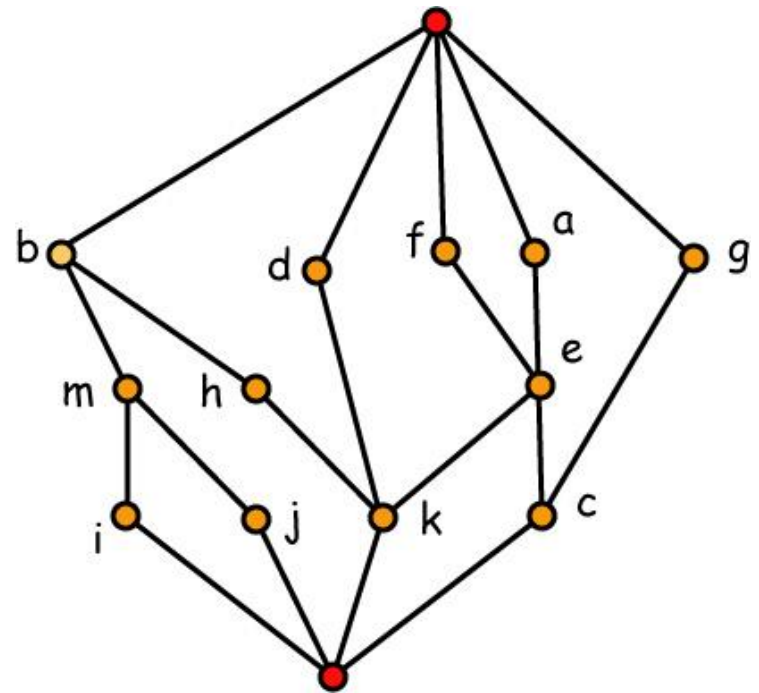

Dimension of Planar Posets (2)

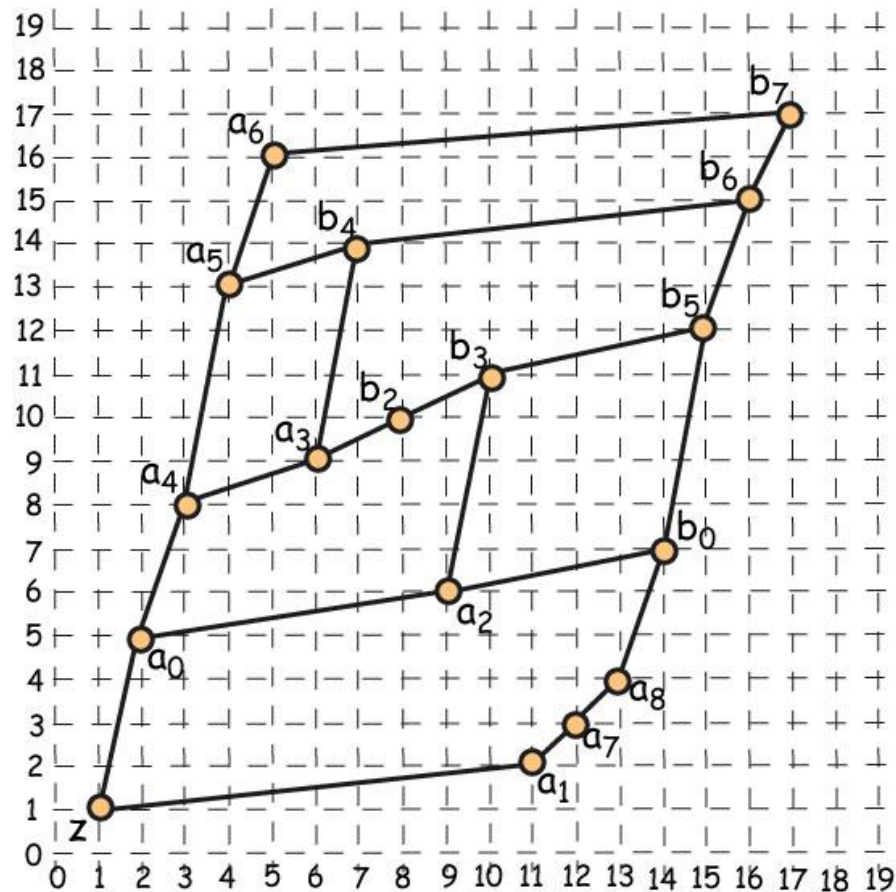

Dimension of Planar Posets (3)

Theorem (Trotter and Moore) If P has a 0 and the diagram of P is planar, then $\dim(P) \leq 3$.

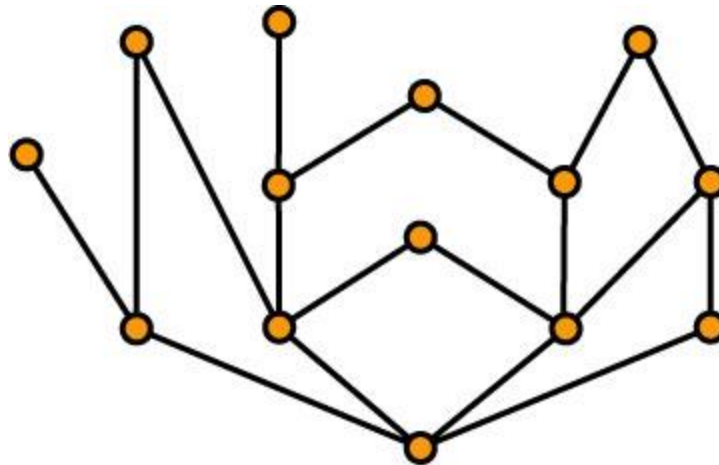

Dimension of Planar Posets (4)

Corollary (Trotter and Moore) If the cover graph of P is a tree, then $\dim(P) \leq 3$.

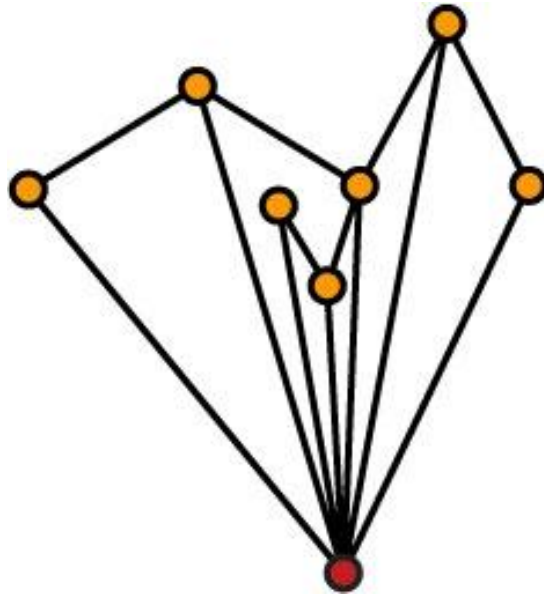

A 4-dimensional planar poset

Fact The standard example S_4 is planar!

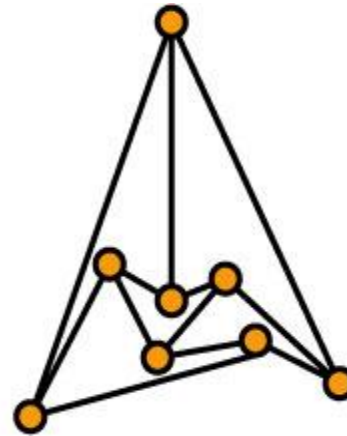
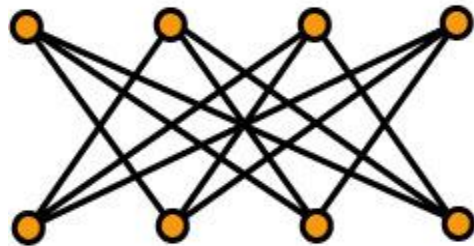

Kelly's Construction

Fact For every $n \geq 5$, the standard example S_n is nonplanar but it is a subposet of a planar poset.

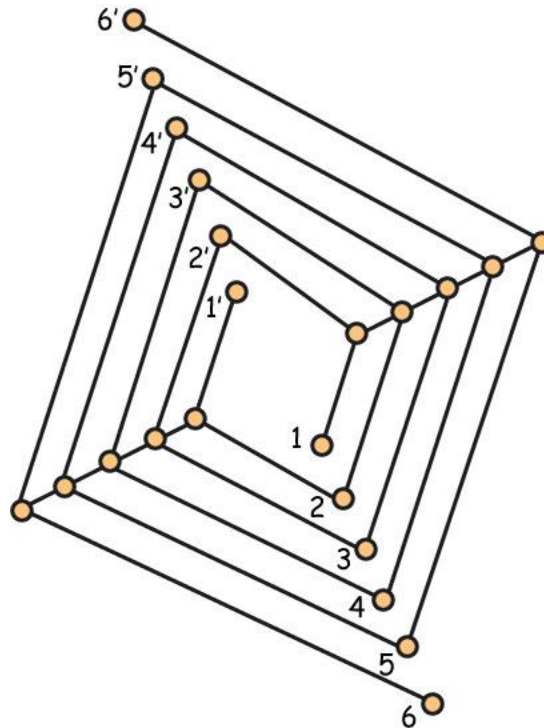

Adjacency Posets

The **adjacency** poset P of a graph $G = (V, E)$ is a height 2 poset with minimal elements $\{x' : x \in V\}$, maximal elements $\{x'' : x \in V\}$, and ordering: $x' < y''$ if and only if $xy \in E$.

Fact If P is the adjacency poset of a graph G , then $\dim(P) \geq \chi(G)$.

Adjacency Posets and Genus

Theorem (Felsner, Li, Trotter) If the acyclic chromatic number of G is a , the dimension of the adjacency poset of G is at most $3a(a-1)/2$.

Theorem (Alon, Mohar, Sanders) The acyclic chromatic number of a graph of genus g is $O(g^{4/7})$.

Corollary For every g , there exists a constant $c(g)$ so that if P is the adjacency poset of a graph of genus g , then $\dim(P) \leq c(g)$.

Adjacency Posets of Planar Graphs



Theorem (Felsner, Li, Trotter) If P is the adjacency poset of a planar graph, then $\dim(P) \leq 8$.

Fact There exists a planar graph whose adjacency poset has dimension 5.

Adjacency Posets of Outerplanar Graphs

Theorem (Felsner, Li, Trotter) If P is the adjacency poset of an outerplanar graph, then $\dim(P) \leq 5$.

Fact There exists an outerplanar graph whose adjacency poset has dimension 4.

Adjacency Posets of Outerplanar Graphs

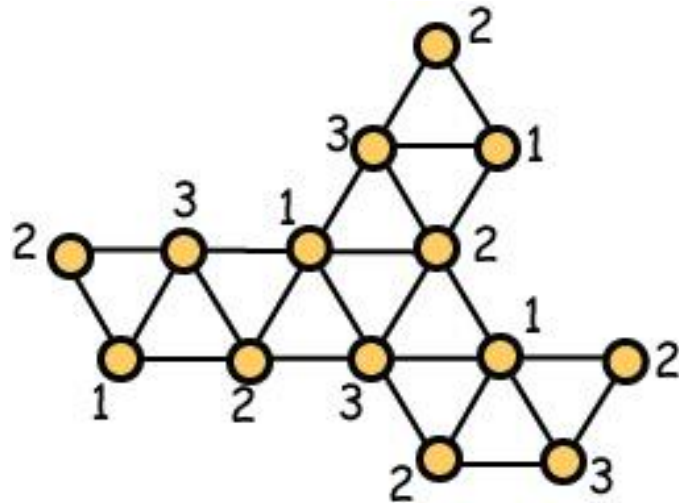

Fact The dimension of the adjacency poset of this outerplanar graph is 4.

Bipartite Planar Graphs

Theorem (Felsner, Li, Trotter) If P is the adjacency poset of a bipartite planar graph, then $\dim(P) \leq 4$.

Corollary (Felsner, Li, Trotter) If P has height 2 and the cover graph of P is planar, then $\dim(P) \leq 4$.

Fact Both results are best possible.

Maximal Elements as Faces

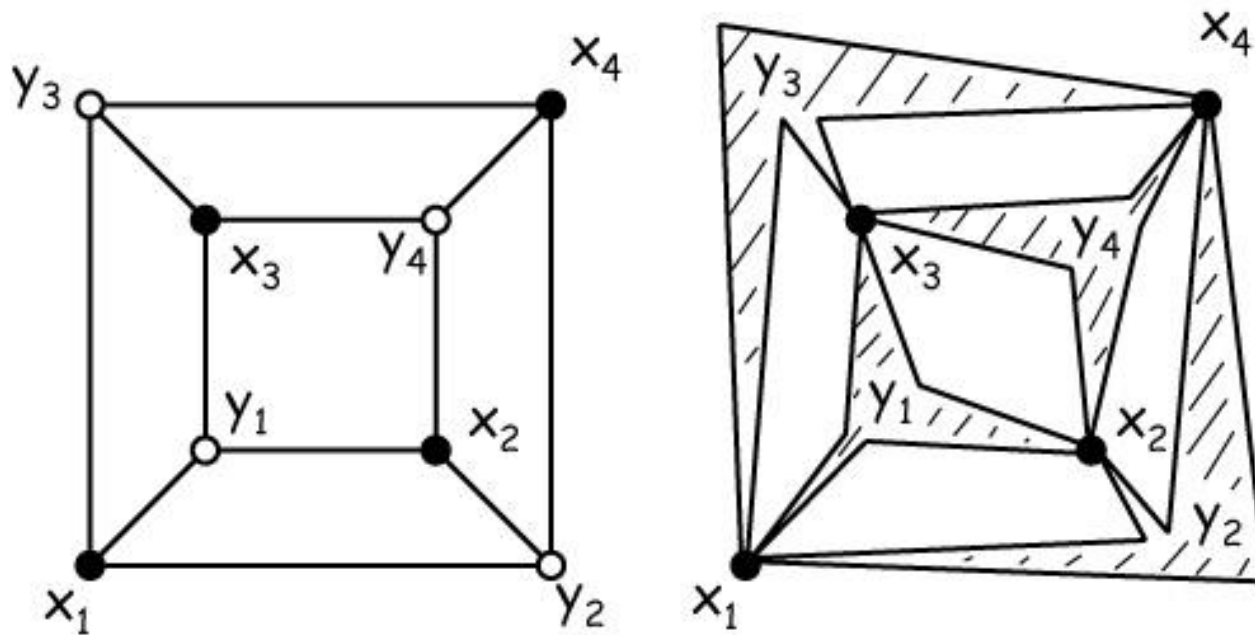

Bipartite Planar Graphs



Theorem (Felsner, Moore, Trotter) If P is a poset of height 2 and the cover graph of P is planar, then P is planar, i.e., the order diagram of P is planar.

Note The result is best possible since there exist height 3 nonplanar posets that have planar cover graphs.

A Non-planar Poset

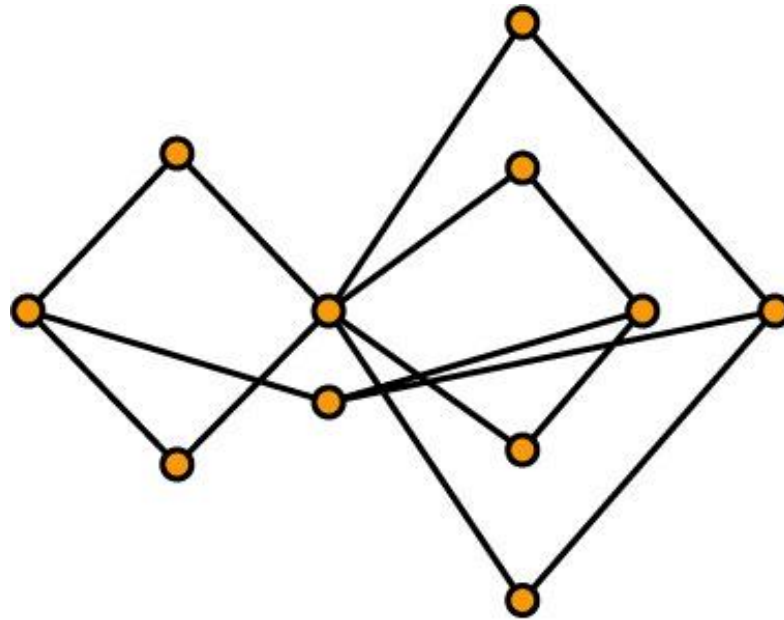

This height 3 non-planar poset has a planar cover graph.

Bipartite Planar Graphs (2)

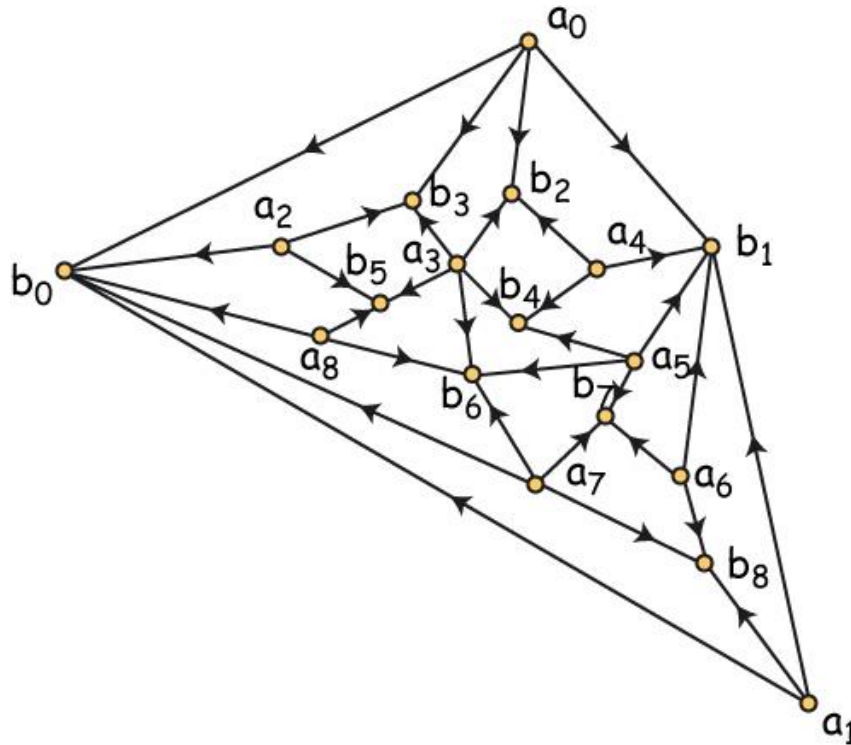

Why should it be possible to draw the order diagram of this height 2 poset without edge crossings?

Dimension and Height

Theorem (Felsner and Trotter) For every integer h , there exists a constant c_h so that if P is a poset of height h and the cover graph of P is planar, then $\dim(P) \leq c_h$.

Fact A straightforward modification to Kelly's construction shows that c_h must be at least $h + 2$.

Kelly's Construction

Fact For every $h \geq 4$, the standard example S_{h-1} is contained in a planar poset of height h .

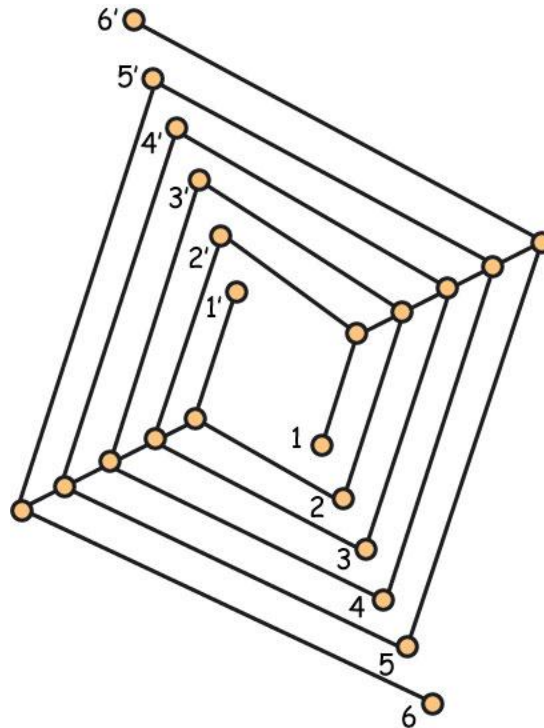

A Modest Improvement

Fact For every $h \geq 2$, the standard example S_{h+2} is contained in a poset of height h having a planar cover graph.

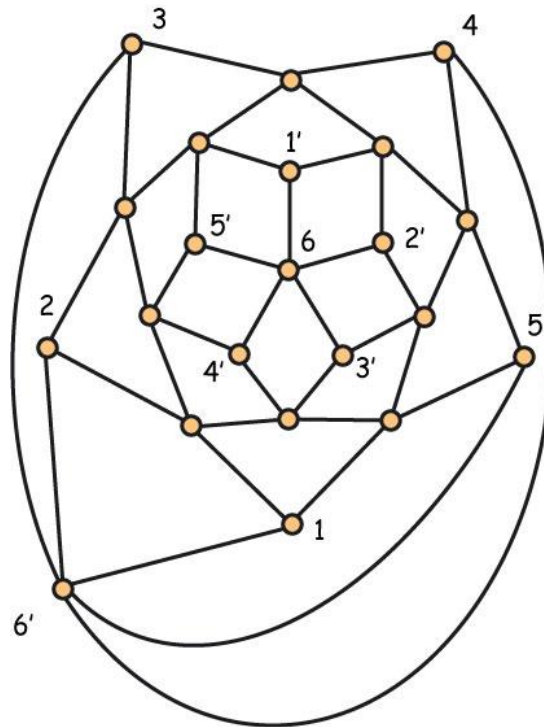

Questions

1. Under what conditions does a poset with a planar cover graph also have a planar diagram?
2. Which posets are subsets of planar posets?
3. For each $t \geq 4$, what is the smallest planar poset having dimension t ?
4. Does a planar poset of large dimension necessarily have large height? **YES!!**