

Discontinuous Dynamical Systems

A tutorial on solutions, nonsmooth analysis, and stability

Jorge Cortés

January 23, 2009

Discontinuous dynamical systems arise in a large number of applications. In optimal control problems, open-loop bang-bang controllers switch discontinuously between extreme values of the inputs to generate minimum-time trajectories from the initial to the final states [1]. Thermostats implement on-off controllers to regulate room temperature [2]. When the temperature is above the desired value, the controller switches the cooling system on. Once the temperature reaches a preset value, the controller switches the cooling system off. The controller is therefore a discontinuous function of the room temperature. In nonsmooth mechanics, the motion of rigid bodies is subject to velocity jumps and force discontinuities as a result of friction and impact [3, 4]. In the robotic manipulation of objects by means of mechanical contact [5], discontinuities occur naturally from interaction with the environment.

Discontinuities are also intentionally designed to achieve regulation and stabilization. Sliding mode control [6, 7] uses discontinuous feedback controllers for stabilization. The design procedure for sliding mode control begins by identifying a surface in the state space with the property that the dynamics of the system restricted to this surface are easily stabilizable. Feedback controllers are then synthesized on each side of the surface to steer the solutions of the system toward the surface. The resulting closed-loop system is discontinuous on the surface. In robotics [8], it is of interest to induce emergent behavior in a swarm of robots by prescribing interaction rules among individual agents. Simple laws such as “move away from the nearest other robot or environmental boundary” give rise to discontinuous dynamical systems. For example, consider a robot placed in a corner of a room. On opposite sides of the bisector line between the two walls forming the corner, the “move away” law translates into different velocity vectors for the robot. The dynamical system is thus discontinuous along the bisector line. In optimization [9, 10], continuous-time algorithms that perform generalized gradient descent, which is a discontinuous function of the state, are used when the objective function is not smooth. In adaptive control [11], switching algorithms are employed to select the most appropriate controller from a given finite family in order to enhance robustness, ensure boundedness of the estimates, and prevent the system from stepping into undesired regions of the state space.

Many control systems cannot be stabilized by continuous state-dependent feedback. As a consequence, it is necessary to consider either time-dependent or discontinuous feedback. As an illustration, consider the one-dimensional system $\dot{x} = X(x, u)$ with an equilibrium at the origin for

$u = 0$. When $x > 0$, we look for u such that $X(x, u) < 0$ (“go left”). Likewise, when $x < 0$, we look for u such that $X(x, u) > 0$ (“go right”). Together, these conditions can be stated as $xX(x, u) < 0$. When the control u appears nonlinearly in X , it may be the case that no continuous state-dependent feedback controller $x \mapsto u(x)$ exists such that $xX(x, u(x)) < 0$ for all $x \in \mathbb{R}$. The following example illustrates the above discussion.

Example 1: System requiring discontinuous stabilization

Consider the one-dimensional system [12]

$$\dot{x} = x[(u - 1)^2 - (x - 1)][(u + 1)^2 + (x - 2)]. \quad (1)$$

The shaded areas in Figure 1 represent the regions in the space (x, u) where $xX(x, u) < 0$. From the plot, it can be seen that there exists no continuous function $x \mapsto u(x)$ defined on \mathbb{R} whose graph belongs to the union of the shaded areas. Even control systems whose inputs appear linearly (see Example 21) may be subject to obstructions that preclude the existence of continuous state-dependent stabilizing feedback [12, 13, 14]. ■

Numerous fundamental questions arise when dealing with discontinuous dynamical systems. The most basic question is the notion of a solution. For a discontinuous vector field, the existence of a continuously differentiable solution, that is, a continuously differentiable curve whose derivative follows the direction of the vector field, is not guaranteed. The following examples illustrate the difficulties that arise in defining solutions of discontinuous dynamical systems.

Example 2: Brick on a frictional ramp

Consider a brick sliding on a ramp [15]. As the brick moves, it experiences a friction force in the opposite direction (see Figure 2(a)). During sliding, the Coulomb friction model states that the magnitude of the friction force is independent of the magnitude of the velocity and is equal to the normal contact force times the coefficient of friction. The application of this model to the sliding brick yields

$$\dot{v}(t) = g(\sin \theta) - \nu g(\cos \theta) \text{sign}(v(t)), \quad (2)$$

where v is the velocity of the brick, g is the acceleration due to gravity, $\theta > 0$ is the inclination of the ramp, ν is the coefficient of friction, and $\text{sign}(0) = 0$. The right-hand side of (2) is a discontinuous function of v because of the presence of the sign function. Figure 2(b) shows the phase plot of this system for several values of ν .

Depending on the magnitude of the friction force, experiments show that the brick stops and stays stopped. In other words, the brick attains $v = 0$ in finite time, and maintains $v = 0$. However, there is no continuously differentiable solution of (2) that exhibits this type of behavior. To see this, note that $v = 0$ and $\dot{v} = 0$ in (2) imply $\sin \theta = 0$, which contradicts $\theta > 0$. In order to explain this type of physical evolution, we need to understand the discontinuity in (2) and expand our notion of solution beyond continuously differentiable solutions. ■

Example 3: Nonsmooth harmonic oscillator

Consider a unit mass subject to a discontinuous spring force. The spring does not exert any force when the mass is at the reference position $x = 0$. When the mass is displaced to the right, that is, $x > 0$, the spring exerts a constant negative force that pulls it back to the reference position. When the mass is displaced to the left, that is, $x < 0$, the spring exerts a constant positive force that pulls it back to the reference position. According to Newton's second law, the system evolution is described by [16]

$$\ddot{x} + \text{sign}(x) = 0. \quad (3)$$

By defining the state variables $x_1 = x$ and $x_2 = \dot{x}$, (3) can be rewritten as

$$\dot{x}_1(t) = x_2(t), \quad (4)$$

$$\dot{x}_2(t) = -\text{sign}(x_1(t)), \quad (5)$$

which is a nonsmooth version of the classical harmonic oscillator. The phase portrait of this system is plotted in Figure 3(a).

It can be seen that $(0, 0)$ is the unique equilibrium of (4)-(5). By discretizing the equations of motion, we find that the trajectories of the system approach, as the time step is made smaller and smaller, the set of curves in Figure 3(b), which are the level sets of the function $(x_1, x_2) \mapsto |x_1| + \frac{x_2^2}{2}$. These level sets are analogous to the level sets of the function $(x_1, x_2) \mapsto x_1^2 + x_2^2$, which are the trajectories of the classical harmonic oscillator $\ddot{x} + x = 0$ [17]. However, the trajectories in Figure 3(b) are not continuously differentiable along the x_2 -coordinate axis since the limiting velocity vectors from the right of the axis and from the left of the axis do not coincide. ■

Example 4: Move-away-from-nearest-neighbor interaction law

Consider n nodes p_1, \dots, p_n evolving in a square Q according to the interaction rule “move diametrically away from the nearest neighbor.” Note that this rule is not defined when two nodes are located at the same point, that is, when the configuration is an element of $SS \triangleq \{(p_1, \dots, p_n) \in Q^n : p_i = p_j \text{ for some } i \neq j\}$. We thus consider only configurations that belong to $Q^n \setminus SS$. Next, we define the map that assigns to each node its nearest neighbor, where the nearest neighbor may be an element of the boundary $\text{bdry}(Q)$ of the square. Note that the nearest neighbor of a node might not be unique, that is, more than one node can be located at the same (nearest) distance. Hence, we define the *nearest-neighbor map* $\mathcal{N} = (\mathcal{N}_1, \dots, \mathcal{N}_n) : Q^n \setminus SS \rightarrow Q^n$ by arbitrarily selecting, for each $i \in \{1, \dots, n\}$, an element,

$$\mathcal{N}_i(p_1, \dots, p_n) \in \text{argmin}\{\|p_i - q\|_2 : q \in \text{bdry}(Q) \cup \{p_1, \dots, p_n\} \setminus \{p_i\}\},$$

where argmin stands for the minimizing value of q , and $\|\cdot\|_2$ denotes the Euclidean norm. By definition, $\mathcal{N}_i(p_1, \dots, p_n) \neq p_i$. For $i \in \{1, \dots, n\}$, we thus define the move-away-from-nearest-neighbor interaction law

$$\dot{p}_i = \frac{p_i(t) - \mathcal{N}_i(p_1(t), \dots, p_n(t))}{\|p_i(t) - \mathcal{N}_i(p_1(t), \dots, p_n(t))\|_2}. \quad (6)$$

Changes in the value of the nearest-neighbor map \mathcal{N} induce discontinuities in the dynamical system. For instance, consider a node sufficiently close to a vertex of $\text{bdry}(Q)$ so that the closest neighbor to the node is an element of the boundary. Depending on how the node is positioned with respect to the bisector line passing through the vertex, the node computes different directions of motion, see Figure 4 for an illustration.

To analyze the dynamical system (6), we need to understand how the discontinuities affect its evolution. Since each node moves away from its nearest neighbors, it is reasonable to expect that the nodes never run into each other, however, rigorous verification of this property requires a proof. We would also like to characterize the asymptotic behavior of the trajectories of the system (6). In order to study these questions, we need to extend our notion of solution. ■

Beyond continuously differentiable solutions

Examples 2-4 above can be described by a dynamical system of the form

$$\dot{x}(t) = X(x(t)), \quad x(t_0) = x_0, \quad (7)$$

where $x \in \mathbb{R}^d$, d is a positive integer, and $X : \mathbb{R}^d \rightarrow \mathbb{R}^d$ is not necessarily continuous. We refer to a continuously differentiable solution $t \mapsto x(t)$ of (7) as *classical*. Clearly, if X is continuous, then every solution is classical. Without loss of generality, we take $t_0 = 0$. We consider only solutions that run forward in time.

Examples 2-4 illustrate the limitations of classical solutions, and confront us with the need to identify a suitable notion for solutions of (7). Unfortunately, there is not a unique answer to this question. Depending on the problem and objective at hand, different notions are appropriate. In this article, we restrict our attention to solutions that are absolutely continuous. Although not treated in detail in this article, it is also possible to consider solutions that admit discontinuities, and hence are not absolutely continuous. These solutions are discussed in “Solutions with Jumps.”

The function $\gamma : [a, b] \rightarrow \mathbb{R}$ is *absolutely continuous* if, for all $\varepsilon \in (0, \infty)$, there exists $\delta \in (0, \infty)$ such that, for each finite collection $\{(a_1, b_1), \dots, (a_n, b_n)\}$ of disjoint open intervals contained in $[a, b]$ with $\sum_{i=1}^n (b_i - a_i) < \delta$, it follows that

$$\sum_{i=1}^n |\gamma(b_i) - \gamma(a_i)| < \varepsilon.$$

Equivalently [12], γ is absolutely continuous if there exists a Lebesgue integrable function $\kappa : [a, b] \rightarrow \mathbb{R}$ such that

$$\gamma(t) = \gamma(a) + \int_a^t \kappa(s) ds, \quad t \in [a, b].$$

Every absolutely continuous function is continuous. However, the converse is not true, since the function $\gamma : [-1, 1] \rightarrow \mathbb{R}$ defined by $\gamma(t) = t \sin(\frac{1}{t})$ for $t \neq 0$ and $\gamma(0) = 0$ is continuous, but not absolutely continuous. Moreover, every continuously differentiable function is absolutely continuous, but the converse is not true. For instance, the function $\gamma : [-1, 1] \rightarrow \mathbb{R}$ defined by $\gamma(t) = |t|$

is absolutely continuous but not continuously differentiable at 0. As this example suggests, every absolutely continuous function is differentiable almost everywhere. Finally, every locally Lipschitz function (see “Locally Lipschitz Functions”) is absolutely continuous, but the converse is not true. For instance, the function $\gamma : [0, 1] \rightarrow \mathbb{R}$ defined by $\gamma(t) = \sqrt{t}$ is absolutely continuous but not locally Lipschitz at 0.

Caratheodory solutions [18] are a generalization of classical solutions. Roughly speaking, Caratheodory solutions are absolutely continuous curves that satisfy the integral version of the differential equation (7), that is,

$$x(t) = x(t_0) + \int_{t_0}^t X(x(s))ds, \quad t > t_0, \quad (8)$$

where the integral is the Lebesgue integral. By using the integral form (8), Caratheodory solutions relax the classical requirement that the solution must follow the direction of the vector field at all times, that is, the differential equation (7) need not be satisfied on a set of measure zero. As shown in this article, Caratheodory solutions exist for Example 3 but do not exist for examples 2 and 4.

Alternatively, Filippov solutions [18] replace the differential equation (7) by a differential inclusion of the form

$$\dot{x}(t) \in \mathcal{F}(x(t)), \quad (9)$$

where $\mathcal{F} : \mathbb{R}^d \rightarrow \mathfrak{B}(\mathbb{R}^d)$ and $\mathfrak{B}(\mathbb{R}^d)$ denotes the collection of all subsets of \mathbb{R}^d . Filippov solutions are absolutely continuous curves. At a given state x , instead of focusing on the value of the vector field at x , the idea behind Filippov solutions is to introduce a set of directions that are determined by the values of the vector field X in a neighborhood of x . Differential inclusions [19, 20] thus involve *set-valued* maps. Just as a standard map or function takes a point in its domain to a *single* point in another space, a set-valued map takes a point in its domain to a *set of points* in another space. A differential inclusion thus specifies that the state derivative belongs to a set of directions, rather than being a specific direction. This flexibility is crucial for providing conditions on the discontinuous vector field under which Filippov solutions exist. This solution notion plays a key role in many of the applications mentioned above, including sliding mode control and mechanics with Coulomb-like friction.

Unfortunately, the obstructions to continuous stabilization illustrated in Example 1 also hold [21, 22] for Filippov solutions. Sample-and-hold solutions [23], which are also absolutely continuous curves, turn out to be the appropriate notion for circumventing these obstructions [24, 25, 26]. “Additional Solution Notions for Discontinuous Systems” describes additional solution notions for discontinuous systems. In this article, we focus on Caratheodory, Filippov, and sample-and-hold solutions.

Existence, uniqueness, and stability of solutions

In addition to the notion of solution, we consider existence and uniqueness of solutions as well as stability. For ordinary differential equations, it is well known that continuity of the vector field

does not guarantee uniqueness. Not surprisingly, no matter what notion of solution is chosen for a discontinuous vector field, nonuniqueness can occur. We thus provide sufficient conditions for uniqueness. We also present results specifically tailored to piecewise continuous vector fields and differential inclusions.

The lack of uniqueness of solutions must be considered when we try to establish properties such as local stability. This issue is reflected in the use of the adjectives weak and strong. The word “weak” is used when a property is satisfied by at least one solution starting from each initial condition. On the other hand, “strong” is used when a property is satisfied by all solutions starting from each initial condition. Therefore, for example, “weakly stable equilibrium point” means that at least one solution starting close to the equilibrium point remains close to it, whereas “strongly stable equilibrium point” means that all solutions starting close to the equilibrium point remain close to it. For detailed definitions, see [14, 18].

We present weak and strong stability results for discontinuous dynamical systems and differential inclusions. As suggested by Example 3, smooth Lyapunov functions do not suffice to analyze the stability of discontinuous systems. This fact leads naturally to the subject of nonsmooth analysis. In particular, we pay special attention to the generalized gradient of a locally Lipschitz function [9] and the proximal subdifferential of a lower semicontinuous function [24]. Building on these notions, weak and strong monotonicity properties of candidate Lyapunov functions can be established along the solutions of discontinuous dynamical systems. These results are used to provide generalizations of Lyapunov stability theorems and the invariance principle, which help us study the stability of solutions. To illustrate the applicability of these results, we discuss in detail a class of nonsmooth gradient flows.

There are two ways to apply the stability results presented here to control systems. The first way is to choose a specific input function and consider the resulting dynamical system. The second way is to associate with the control system the set-valued map that assigns each state to the set of all vectors generated by the allowable inputs, and consider the resulting differential inclusion. Rather than focusing on a particular input, this viewpoint allows us to consider the full range of trajectories of the control system. To analyze the stability of the control system under this approach, we can use the nonsmooth tools developed for differential inclusions. We explore this idea in detail.

Given the large body of work on discontinuous systems, our aim is to provide a clear exposition of a few useful and central results. “Additional Topics on Discontinuous Systems and Differential Inclusions” briefly discusses issues that are not considered in the main exposition.

Organization of this article

We start by reviewing basic results on the existence and uniqueness of classical, that is, continuously differentiable, solutions of ordinary differential equations. We also present several examples in which the vector field fails to satisfy the standard smoothness properties. We then introduce various notions of solution for discontinuous systems, discuss existence and uniqueness results, and present useful tools for analysis. In preparation for the statement of stability results, we introduce the generalized gradient and proximal subdifferential from nonsmooth analysis, and present various

tools for their explicit computation. Then, we develop analysis results to characterize the stability and asymptotic convergence properties of the solutions of discontinuous dynamical systems. We illustrate these nonsmooth stability results by means of examples, paying special attention to gradient systems. Throughout the discussion, we interchangeably use “differential equation,” “dynamical system,” and “vector field.” For reference, “Index of Symbols” summarizes the notation used throughout.

To simplify the presentation, we have chosen to restrict our attention to time-invariant vector fields, although most of the development can be adapted to the time-varying setting. We briefly discuss time-varying systems in “Caratheodory Conditions for Time-varying Vector Fields” and “Caratheodory Solutions of Differential Inclusions.” Likewise, for simplicity, we mostly consider vector fields defined over the whole Euclidean space, although the exposition can be carried out in more general settings such as open and connected subsets of the Euclidean space.

Existence and Uniqueness for Ordinary Differential Equations

In this section, we review basic results on existence and uniqueness of classical solutions for ordinary differential equations. We also present examples that do not satisfy the hypotheses of these results but nevertheless exhibit existence and uniqueness of classical solutions, as well as examples that do not possess such desirable properties.

Existence of classical solutions

Consider the differential equation

$$\dot{x}(t) = X(x(t)), \tag{10}$$

where $X : \mathbb{R}^d \rightarrow \mathbb{R}^d$ is a vector field. The point $x_e \in \mathbb{R}^d$ is an *equilibrium* of (10) if $0 = X(x_e)$. A *classical solution* of (10) on $[0, t_1]$ is a continuously differentiable map $x : [0, t_1] \rightarrow \mathbb{R}^d$ that satisfies (10). Note that, without loss of generality, we consider only solutions that start at time 0. Usually, we refer to $t \mapsto x(t)$ as a classical solution with initial condition $x(0)$. We sometimes write the initial condition as x_0 instead of $x(0)$. The solution $t \mapsto x(t)$ is *maximal* if it cannot be extended forward in time, that is, if $t \mapsto x(t)$ is not the result of the truncation of another solution with a larger interval of definition. Note that the interval of definition of a maximal solution is either of the form $[0, T)$, where $T > 0$, or $[0, \infty)$.

Continuity of the vector field suffices to guarantee the existence of classical solutions, as stated by Peano’s theorem [27].

Proposition 1. *Let $X : \mathbb{R}^d \rightarrow \mathbb{R}^d$ be continuous. Then, for all $x_0 \in \mathbb{R}^d$, there exists a classical solution of (10) with initial condition $x(0) = x_0$.*

The following example shows that, if the vector field is discontinuous, then classical solutions of (10) might not exist.

Example 5: Discontinuous vector field with nonexistence of classical solutions

Consider the vector field $X : \mathbb{R} \rightarrow \mathbb{R}$ defined by

$$X(x) = \begin{cases} -1, & x > 0, \\ 1, & x \leq 0, \end{cases} \quad (11)$$

which is discontinuous at 0 (see Figure 5(a)). Suppose that there exists a continuously differentiable function $x : [0, t_1] \rightarrow \mathbb{R}$ such that $\dot{x}(t) = X(x(t))$ and $x(0) = 0$. Then $\dot{x}(0) = X(x(0)) = X(0) = 1$, which implies that, for all positive t sufficiently small, $x(t) > 0$ and hence $\dot{x}(t) = X(x(t)) = -1$, which contradicts the fact that $t \mapsto \dot{x}(t)$ is continuous. Hence, no classical solution starting from 0 exists. ■

In contrast to Example 5, the following example shows that the lack of continuity of the vector field does not preclude the existence of classical solutions.

Example 6: Discontinuous vector field with existence of classical solutions

Consider the vector field $X : \mathbb{R} \rightarrow \mathbb{R}$,

$$X(x) = -\text{sign}(x) = \begin{cases} -1, & x > 0, \\ 0, & x = 0, \\ 1, & x < 0, \end{cases} \quad (12)$$

which is discontinuous at 0 (see Figure 5(b)). If $x(0) > 0$, then the maximal solution $x : [0, x(0)) \rightarrow \mathbb{R}$ is $x(t) = x(0) - t$, whereas, if $x(0) < 0$, then the maximal solution $x : [0, -x(0)) \rightarrow \mathbb{R}$ is $x(t) = x(0) + t$. Finally, if $x(0) = 0$, then the maximal solution $x : [0, \infty) \rightarrow \mathbb{R}$ is $x(t) = 0$. Hence the associated dynamical system $\dot{x}(t) = X(x(t))$ has a classical solution starting from every initial condition. Although the vector fields (11) and (12) are identical except for the value at 0, the existence of classical solutions is surprisingly different. ■

Uniqueness of classical solutions

Uniqueness of classical solutions of the differential equation (10) means that every pair of solutions with the same initial condition coincide on the intersection of their intervals of existence. In other words, if $x_1 : [0, t_1] \rightarrow \mathbb{R}^d$ and $x_2 : [0, t_2] \rightarrow \mathbb{R}^d$ are classical solutions of (10) with $x_1(0) = x_2(0)$, then $x_1(t) = x_2(t)$ for all $t \in [0, t_1] \cap [0, t_2] = [0, \min\{t_1, t_2\}]$. Equivalently, we say that there exists a unique maximal solution starting from each initial condition.

Uniqueness of classical solutions is guaranteed under a wide variety of conditions. The book [28], for instance, is devoted to collecting various uniqueness criteria. Here, we focus on a uniqueness criterion based on one-sided Lipschitzness. The vector field $X : \mathbb{R}^d \rightarrow \mathbb{R}^d$ is *one-sided Lipschitz* on $U \subset \mathbb{R}^d$ if there exists $L > 0$ such that, for all $y, y' \in U$,

$$[X(y) - X(y')]^T (y - y') \leq L \|y - y'\|_2^2. \quad (13)$$

This property is one-sided because it imposes a requirement on X only when the angle between the two vectors on the left-hand side of (13) is between 0 and 180 degrees. The following result, given in [28], uses this property to provide a sufficient condition for uniqueness.

Proposition 2. *Let $X : \mathbb{R}^d \rightarrow \mathbb{R}^d$ be continuous. Assume that, for all $x \in \mathbb{R}^d$, there exists $\varepsilon > 0$ such that X is one-sided Lipschitz on $B(x, \varepsilon)$. Then, for all $x_0 \in \mathbb{R}^d$, there exists a unique classical solution of (10) with initial condition $x(0) = x_0$.*

Every vector field that is locally Lipschitz at x (see “Locally Lipschitz Functions”) satisfies the one-sided Lipschitz condition on a neighborhood of x , but the converse is not true. For example, the vector field $X : \mathbb{R} \rightarrow \mathbb{R}$ defined by $X(0) = 0$ and $X(x) = x \log(|x|)$ for $x \neq 0$ is one-sided Lipschitz on a neighborhood of 0, but is not locally Lipschitz at 0. Furthermore, a one-sided Lipschitz vector field can be discontinuous. For example, the discontinuous vector field (12) is one-sided Lipschitz on a neighborhood of 0.

The following result is an immediate consequence of Proposition 2.

Corollary 1. *Let $X : \mathbb{R}^d \rightarrow \mathbb{R}^d$ be locally Lipschitz. Then, for all $x_0 \in \mathbb{R}^d$, there exists a unique classical solution of (10) with initial condition $x(0) = x_0$.*

Although local Lipschitzness is typically invoked as in Corollary 1 to guarantee uniqueness, Proposition 2 shows that uniqueness is guaranteed under weaker hypotheses. The following example shows that, if the hypotheses of Proposition 2 are not satisfied, then solutions might not be unique.

Example 7: Continuous, not one-sided Lipschitz vector field with nonunique classical solutions

Consider the vector field $X : \mathbb{R} \rightarrow \mathbb{R}$ defined by

$$X(x) = \sqrt{|x|}. \tag{14}$$

This vector field is continuous everywhere, locally Lipschitz on $\mathbb{R} \setminus \{0\}$ (see Figure 5(c)), but is neither locally Lipschitz at 0 nor one-sided Lipschitz on any neighborhood of 0. The associated dynamical system $\dot{x}(t) = X(x(t))$ has infinitely many maximal solutions starting from 0, namely, for all $a > 0$, $x_a : [0, \infty) \rightarrow \mathbb{R}$, where

$$x_a(t) = \begin{cases} 0, & 0 \leq t \leq a, \\ (t - a)^2/4, & t \geq a, \end{cases}$$

and $x : [0, \infty) \rightarrow \mathbb{R}$, where $x(t) = 0$. ■

However, the following example shows that a differential equation can possess a unique classical solution even when the hypotheses of Proposition 2 are not satisfied.

Example 8: Continuous, not one-sided Lipschitz vector field with unique classical solutions

Consider the vector field $X : \mathbb{R} \rightarrow \mathbb{R}$ defined by

$$X(x) = \begin{cases} -x \log x, & x > 0, \\ 0, & x = 0, \\ x \log(-x), & x < 0. \end{cases} \quad (15)$$

This vector field is continuous everywhere, and locally Lipschitz on $\mathbb{R} \setminus \{0\}$ (see Figure 5(d)). However, X is not locally Lipschitz at 0 nor one-sided Lipschitz on any neighborhood of 0. Nevertheless, the associated dynamical system $\dot{x}(t) = X(x(t))$ has a unique solution starting from each initial condition. If $x(0) > 0$, then the maximal solution $x : [0, \infty) \rightarrow \mathbb{R}$ is $x(t) = \exp(\log x(0) \exp(-t))$, whereas, if $x(0) < 0$, then the maximal solution $x : [0, \infty) \rightarrow \mathbb{R}$ is $x(t) = -\exp(\log(-x(0)) \exp(t))$. Finally, if $x(0) = 0$, then the maximal solution $x : [0, \infty) \rightarrow \mathbb{R}$ is $x(t) = 0$. ■

Note that Proposition 2 assumes that the vector field is continuous. However, the discontinuous vector field (12) in Example 6 is one-sided Lipschitz in a neighborhood of 0 and, indeed, has a unique classical solution starting from each initial condition. This observation suggests that discontinuous systems are not necessarily more complicated or less “well-behaved” than continuous systems. The continuous system (14) in Example 7 does not have a unique classical solution starting from each initial condition, whereas the discontinuous system (12) in Example 6 does. A natural question to ask is under what conditions does a discontinuous vector field have a unique solution starting from each initial condition. Of course, the answer to this question relies on the notion of solution itself. We explore these questions in the next section.

Notions of Solution for Discontinuous Dynamical Systems

The above discussion shows that the classical notion of solution is too restrictive when considering a discontinuous vector field. We thus explore alternative notions of solution to reconcile this mismatch. To address the discontinuities of the differential equation (10), we first relax the requirement that solutions follow the direction specified by the vector field at all times. The precise mathematical notion corresponding to this idea is that of Caratheodory solutions, which we introduce next.

Caratheodory solutions

A *Caratheodory solution* of (10) defined on $[0, t_1] \subset \mathbb{R}$ is an absolutely continuous map $x : [0, t_1] \rightarrow \mathbb{R}^d$ that satisfies (10) for almost all $t \in [0, t_1]$ (in the sense of Lebesgue measure). In other words, a Caratheodory solution follows the direction specified by the vector field except for a set of time instants that has measure zero. Equivalently, Caratheodory solutions are absolutely

continuous functions that solve the integral version of (10), that is,

$$x(t) = x(0) + \int_0^t X(x(s))ds. \tag{16}$$

Of course, every classical solution is also a Caratheodory solution.

Example 9: System with Caratheodory solutions and no classical solutions

The vector field $X : \mathbb{R} \rightarrow \mathbb{R}$ defined by

$$X(x) = \begin{cases} 1, & x > 0, \\ \frac{1}{2}, & x = 0, \\ -1, & x < 0, \end{cases}$$

is discontinuous at 0. The associated dynamical system $\dot{x}(t) = X(x(t))$ does not have a classical solution starting from 0. However, this system has two Caratheodory solutions starting from 0, namely, $x_1 : [0, \infty) \rightarrow \mathbb{R}$, where $x_1(t) = t$, and $x_2 : [0, \infty) \rightarrow \mathbb{R}$, where $x_2(t) = -t$. Note that both x_1 and x_2 violate the differential equation only at $t = 0$, that is, $\dot{x}_1(0) \neq X(x_1(0))$ and $\dot{x}_2(0) \neq X(x_2(0))$. ■

Example 3 revisited: Existence of Caratheodory solutions for the nonsmooth harmonic oscillator

The nonsmooth harmonic oscillator in Example 3 does not possess a classical solution starting from any initial condition on the x_2 -axis. However, the closed level sets depicted in Figure 3(b), when traversed clockwise, are Caratheodory solutions. ■

Unfortunately, the good news is quickly over since it is easy to find examples of discontinuous dynamical systems that do not admit Caratheodory solutions. For example, the physical motions observed in Example 2, where the brick slides for a while and then remains stopped, are not Caratheodory solutions. Furthermore, the discontinuous vector field (11) does not admit a Caratheodory solution starting from 0. Finally, the move-away-from-nearest-neighbor interaction law in Example 4 is yet another example where Caratheodory solutions do not exist, as we show next.

Example 4 revisited: Nonexistence of Caratheodory solutions for the move-away-from-nearest-neighbor interaction law

Consider one agent moving in the square $[-1, 1]^2 \subset \mathbb{R}^2$ under the move-away-from-nearest-neighbor interaction law described in Example 4. Since no other agent is present in the square, the

agent moves away from the nearest polygonal boundary, according to the vector field

$$X(x_1, x_2) = \begin{cases} (-1, 0), & -x_1 < x_2 \leq x_1, \\ (0, 1), & x_2 < x_1 \leq -x_2, \\ (1, 0), & x_1 \leq x_2 < -x_1, \\ (0, -1), & -x_2 \leq x_1 < x_2. \end{cases} \quad (17)$$

Since the move-away-from-nearest-neighbor interaction law takes multiple values on the diagonals $\{(a, \pm a) \in [-1, 1]^2 : a \in [-1, 1]\}$ of the square, we choose one of these values in the definition (17) of X . The phase portrait in Figure 6(a) shows that the vector field X is discontinuous on the diagonals.

The dynamical system $\dot{x}(t) = X(x(t))$ has no Caratheodory solution if and only if the initial condition belongs to the diagonals. This fact can be justified as follows. Consider the four open regions of the square separated by the diagonals, see Figure 6(a). On the one hand, if the initial condition belongs to one of these regions, then the dynamical system has a classical solution; depending on which region the initial condition belongs to, the agent moves either vertically or horizontally toward the diagonals. On the other hand, on the diagonals of the square, X pushes trajectories outward, whereas, outside the diagonals, X pushes trajectories inward. Therefore, if the initial condition belongs to the diagonals, then the only candidate trajectory for a Caratheodory solution is a trajectory that moves along the diagonals. From the definition (16) of Caratheodory solution, it is clear that a trajectory that moves along the diagonals of the square is not a Caratheodory solution. We show later that this trajectory is instead a Filippov solution. ■

Sufficient conditions for the existence of Caratheodory solutions

Conditions under which Caratheodory solutions exist are discussed in “Caratheodory Conditions for Time-varying Vector Fields.” For time-invariant vector fields, the Caratheodory conditions given by Proposition S1 specialize to continuity of the vector field. This requirement provides no improvement over Proposition 1, which guarantees the existence of classical solutions under continuity.

Therefore, it is of interest to determine conditions for the existence of Caratheodory solutions specifically tailored to time-invariant vector fields. For example, directionally continuous vector fields are considered in [29]. A vector field $X : \mathbb{R}^d \rightarrow \mathbb{R}^d$ is *directionally continuous* if there exists $\delta \in (0, \infty)$ such that, for every $x \in \mathbb{R}^d$ with $X(x) \neq 0$ and every sequence $\{x_n\}_{n \in \mathbb{N}} \subset \mathbb{R}^d$ with $x_n \rightarrow x$ and

$$\left\| \frac{x_n - x}{\|x_n - x\|_2} - \frac{X(x)}{\|X(x)\|_2} \right\|_2 < \delta, \quad n \in \mathbb{N}, \quad (18)$$

it follows that $X(x_n) \rightarrow X(x)$. If the vector field X is directionally continuous, then, for all $x_0 \in \mathbb{R}^d$, there exists a Caratheodory solution of (10) with initial condition $x(0) = x_0$.

Patchy vector fields [30] are another class of time-invariant, discontinuous vector fields that have Caratheodory solutions. Additional conditions for the existence and uniqueness of Caratheodory

conditions can be found in [31, 32, 33]. Beyond differential equations, Caratheodory solutions can also be defined for differential inclusions, as explained in “Set-valued Maps” and “Caratheodory Solutions of Differential Inclusions.”

Filippov solutions

The above discussion shows that the relaxation of the value of the vector field on a set of times of measure zero in the definition of Caratheodory solution is not always sufficient to guarantee that such solutions exist. Due to the discontinuity of the vector field, its value can exhibit significant variations arbitrarily close to a given point, and this mismatch might make it impossible to construct a Caratheodory solution.

What if, instead of focusing on the value of the vector field at individual points, we consider how the vector field looks like *around* each point? The idea of looking at a neighborhood of each point is at the core of the notion of Filippov solution [18]. Closely related notions are those of Krasovskii solution [34] and Senti solution [35].

The mathematical framework for formalizing this neighborhood idea uses set-valued maps. The idea is to associate a set-valued map to $X : \mathbb{R}^d \rightarrow \mathbb{R}^d$ by looking at the neighboring values of X around each point. Specifically, for $x \in \mathbb{R}^d$, the vector field X is evaluated at the points belonging to $B(x, \delta)$, which is the open ball centered at x with radius $\delta > 0$. We examine the effect of δ approaching 0 by performing this evaluation for smaller and smaller δ . For additional flexibility, we exclude an arbitrary set of measure zero in $B(x, \delta)$ when evaluating X , so that the outcome is the same for two vector fields that differ on a set of measure zero.

Mathematically, the above procedure can be summarized as follows. Let $\mathfrak{B}(\mathbb{R}^d)$ denote the collection of subsets of \mathbb{R}^d . For $X : \mathbb{R}^d \rightarrow \mathbb{R}^d$, define the *Filippov set-valued map* $F[X] : \mathbb{R}^d \rightarrow \mathfrak{B}(\mathbb{R}^d)$ by

$$F[X](x) \triangleq \bigcap_{\delta > 0} \bigcap_{\mu(S)=0} \overline{\text{co}}\{X(B(x, \delta) \setminus S)\}, \quad x \in \mathbb{R}^d. \quad (19)$$

In (19), $\overline{\text{co}}$ denotes convex closure, and μ denotes Lebesgue measure. Because of the way the Filippov set-valued map is defined, the value of $F[X]$ at a point x is independent of the value of the vector field X at x .

Examples 5 and 6 revisited: Filippov set-valued map of the sign function

Let us compute the Filippov set-valued map for the vector fields (11) and (12). Since both vector fields differ only at 0, which is a set of measure zero, their associated Filippov set-valued maps are identical and equal to $F[X] : \mathbb{R} \rightarrow \mathfrak{B}(\mathbb{R})$, where

$$F[X](x) = \begin{cases} -1, & x > 0, \\ [-1, 1], & x = 0, \\ 1, & x < 0. \end{cases} \quad (20)$$

Note that this Filippov set-valued map is multiple-valued only at the point of discontinuity of the vector field. This observation is valid for all vector fields. ■

We are now ready to handle the discontinuities of the vector field X by using the Filippov set-valued map of X . We replace the differential equation $\dot{x}(t) = X(x(t))$ by the differential inclusion

$$\dot{x}(t) \in F[X](x(t)). \quad (21)$$

A *Filippov solution* of (10) on $[0, t_1] \subset \mathbb{R}$ is an absolutely continuous map $x : [0, t_1] \rightarrow \mathbb{R}^d$ that satisfies (21) for almost all $t \in [0, t_1]$. Equivalently, a Filippov solution of (10) is a Caratheodory solution of the differential inclusion (21), see “Caratheodory Solutions of Differential Inclusions.”

Because of the way the Filippov set-valued map is defined, a vector field that differs from X on a set of measure zero has the same Filippov set-valued map, and hence the same set of solutions. The next result establishes mild conditions under which Filippov solutions exist [18, 19].

Proposition 3. *Let $X : \mathbb{R}^d \rightarrow \mathbb{R}^d$ be measurable and locally essentially bounded, that is, bounded on a bounded neighborhood of every point, excluding sets of measure zero. Then, for all $x_0 \in \mathbb{R}^d$, there exists a Filippov solution of (10) with initial condition $x(0) = x_0$.*

In Proposition 3, the hypotheses on the vector field imply that the associated Filippov set-valued map satisfies all of the hypotheses of Proposition S1 (see “Caratheodory Solutions of Differential Inclusions”), which in turn guarantees the existence of Filippov solutions.

Examples 5 and 6 revisited: Existence of Filippov solutions for the sign function

The application of Proposition 3 to the bounded vector fields in examples 5 and 6 guarantees that a Filippov solution of (10) exists for both examples starting from each initial condition. Furthermore, since the vector fields (11) and (12) have the same Filippov set-valued map (20), examples 5 and 6 have the same maximal Filippov solutions. If $x(0) > 0$, then the maximal solution $x : [0, \infty) \rightarrow \mathbb{R}$ is

$$x(t) = \begin{cases} x(0) - t, & t \leq x(0), \\ 0, & t \geq x(0), \end{cases}$$

whereas, if $x(0) < 0$, then the maximal solution $x : [0, \infty) \rightarrow \mathbb{R}$ is

$$x(t) = \begin{cases} x(0) + t, & t \leq -x(0), \\ 0, & t \geq -x(0). \end{cases}$$

Finally, if $x(0) = 0$, then the maximal solution $x : [0, \infty) \rightarrow \mathbb{R}$ is $x(t) = 0$. ■

Similar computations can be made for the move-away-from-nearest-neighbor interaction law in Example 4 to show that Filippov solutions exist starting from each initial condition, as we show next.

Example 4 revisited: Filippov solutions for the move-away-from-nearest-neighbor interaction law

Consider again the discontinuous vector field for one agent moving in the square $[-1, 1]^2 \subset \mathbb{R}^2$ under the move-away-from-nearest-neighbor interaction law described in Example 4. The corresponding set-valued map $F[X] : [-1, 1]^2 \rightarrow \mathfrak{B}(\mathbb{R}^2)$ is given by

$$F[X](x_1, x_2) = \begin{cases} \{(y_1, y_2) \in \mathbb{R}^2 : |y_1 + y_2| \leq 1, |y_1 - y_2| \leq 1\}, & (x_1, x_2) = (0, 0), \\ \{(-1, 0)\}, & -x_1 < x_2 < x_1, \\ \{(y_1, y_2) \in \mathbb{R}^2 : y_1 + y_2 = -1, y_1 \in [-1, 0]\}, & 0 < x_2 = x_1, \\ \{(0, 1)\}, & x_2 < x_1 < -x_2, \\ \{(y_1, y_2) \in \mathbb{R}^2 : y_1 - y_2 = -1, y_1 \in [-1, 0]\}, & 0 < -x_1 = x_2, \\ \{(1, 0)\}, & x_1 < x_2 < -x_1, \\ \{(y_1, y_2) \in \mathbb{R}^2 : y_1 + y_2 = 1, y_1 \in [0, 1]\}, & x_2 = x_1 < 0, \\ \{(0, -1)\}, & -x_2 < x_1 < x_2, \\ \{(y_1, y_2) \in \mathbb{R}^2 : y_1 - y_2 = 1, y_1 \in [0, 1]\}, & 0 < x_1 = -x_2. \end{cases} \quad (22)$$

Since X is bounded, it follows from Proposition 3 that a Filippov solution exists starting from each initial condition, see Figure 6(b). In particular, each solution starting from a point on a diagonal is a straight line flowing along the diagonal itself and reaching $(0, 0)$. For example, the maximal solution $x : [0, \infty) \rightarrow \mathbb{R}^2$ starting from $(a, a) \in \mathbb{R}^2$ is given by

$$t \mapsto x(t) = \begin{cases} (a - \frac{1}{2} \text{sign}(a)t, a - \frac{1}{2} \text{sign}(a)t), & t \leq |a|, \\ (0, 0), & t \geq |a|. \end{cases} \quad (23)$$

Note that the solution *slides* along the diagonals, following a convex combination of the limiting values of X around the diagonals, rather than the direction specified by X itself. We study this type of behavior in more detail in the section “Piecewise continuous vector fields and sliding motions.”

■

Relationship between Caratheodory and Filippov solutions

In general, Caratheodory and Filippov solutions are not related. A vector field for which both notions of solution exist but Filippov solutions are not Caratheodory solutions is given in [30]. The following is an example of the opposite case.

Example 10: Vector field with a Caratheodory solution that is not a Filippov solution

Consider the vector field $X : \mathbb{R} \rightarrow \mathbb{R}$ given by

$$X(x) = \begin{cases} 1, & x \neq 0, \\ 0, & x = 0. \end{cases} \quad (24)$$

The dynamical system (10) has two Caratheodory solutions starting from 0, namely, $x_1 : [0, \infty) \rightarrow \mathbb{R}$, where $x_1(t) = 0$, and $x_2 : [0, \infty) \rightarrow \mathbb{R}$, where $x_2(t) = t$. However, the associated Filippov set-valued map $F[X] : \mathbb{R} \rightarrow \mathfrak{B}(\mathbb{R})$ is $F[X](x) = \{1\}$, and hence $t \mapsto x_2(t)$ is the unique Filippov solution starting from 0. ■

On a related note, Caratheodory solutions are always Krasovskii solutions (see “Additional Solution Notions for Discontinuous Systems”) but the converse is not true [16].

Computing the Filippov set-valued map

Computing the Filippov set-valued map can be a daunting task. A calculus is developed in [36] to simplify this calculation. We summarize some useful facts below. Note that the Filippov set-valued map can also be constructed for maps of the form $X : \mathbb{R}^d \rightarrow \mathbb{R}^m$, where d and m are not necessarily equal.

Consistency. If $X : \mathbb{R}^d \rightarrow \mathbb{R}^m$ is continuous at $x \in \mathbb{R}^d$, then

$$F[X](x) = \{X(x)\}. \quad (25)$$

Sum rule. If $X_1, X_2 : \mathbb{R}^d \rightarrow \mathbb{R}^m$ is locally bounded at $x \in \mathbb{R}^d$, then

$$F[X_1 + X_2](x) \subseteq F[X_1](x) + F[X_2](x). \quad (26)$$

Moreover, if either X_1 or X_2 is continuous at x , then equality holds.

Product rule. If $X_1 : \mathbb{R}^d \rightarrow \mathbb{R}^m$ and $X_2 : \mathbb{R}^d \rightarrow \mathbb{R}^n$ are locally bounded at $x \in \mathbb{R}^d$, then

$$F[(X_1, X_2)^T](x) \subseteq F[X_1](x) \times F[X_2](x). \quad (27)$$

Moreover, if either X_1 or X_2 is continuous at x , then equality holds.

Chain rule. If $Y : \mathbb{R}^d \rightarrow \mathbb{R}^n$ is continuously differentiable at $x \in \mathbb{R}^d$ with Jacobian rank n , and $X : \mathbb{R}^n \rightarrow \mathbb{R}^m$ is locally bounded at $Y(x) \in \mathbb{R}^n$, then

$$F[X \circ Y](x) = F[X](Y(x)). \quad (28)$$

Matrix transformation rule. If $X : \mathbb{R}^d \rightarrow \mathbb{R}^m$ is locally bounded at $x \in \mathbb{R}^d$ and $Z : \mathbb{R}^d \rightarrow \mathbb{R}^{d \times m}$ is continuous at $x \in \mathbb{R}^d$, then

$$F[Z X](x) = Z(x) F[X](x). \quad (29)$$

Piecewise continuous vector fields and sliding motions

In this section we consider vector fields that are continuous everywhere except on a surface of the state space. Consider, for instance, two continuous dynamical systems, one per side of the surface,

glued together to give rise to a discontinuous dynamical system. Here, we analyze the properties of the Filippov solutions of this type of systems.

The vector field $X : \mathbb{R}^d \rightarrow \mathbb{R}^d$ is *piecewise continuous* if there exists a finite collection of disjoint, open, and connected sets $\mathcal{D}_1, \dots, \mathcal{D}_m \subset \mathbb{R}^d$ whose closures cover \mathbb{R}^d , that is, $\mathbb{R}^d = \bigcup_{k=1}^m \overline{\mathcal{D}_k}$, such that, for all $k = 1, \dots, m$, the vector field X is continuous on \mathcal{D}_k . We further assume that the restriction of X to \mathcal{D}_k admits a continuous extension to the closure $\overline{\mathcal{D}_k}$, which we denote by $X|_{\overline{\mathcal{D}_k}}$. Every point of discontinuity of X must therefore belong to the union of the boundaries of the sets $\mathcal{D}_1, \dots, \mathcal{D}_m$. Let us denote by $S_X \subseteq \text{bdry}(\mathcal{D}_1) \cup \dots \cup \text{bdry}(\mathcal{D}_m)$ the set of points where X is discontinuous. Note that S_X has measure zero.

The Filippov set-valued map of a piecewise continuous vector field X is given by the expression

$$F[X](x) = \overline{\text{co}}\{\lim_{i \rightarrow \infty} X(x_i) : x_i \rightarrow x, x_i \notin S_X\}. \quad (30)$$

This set-valued map can be computed as follows. At points of continuity of X , that is, for $x \notin S_X$, the consistency property (25) implies that $F[X](x) = \{X(x)\}$. At points of discontinuity of X , that is, for $x \in S_X$, $F[X](x)$ is a convex polyhedron in \mathbb{R}^d of the form

$$F[X](x) = \text{co}\{X|_{\overline{\mathcal{D}_k}}(x) : x \in \text{bdry}(\mathcal{D}_k)\}. \quad (31)$$

As an illustration, let us revisit examples 2-4.

Examples 2-4 revisited: Computation of the Filippov set-valued map and Filippov solutions

The vector field of the sliding brick in Example 2 is piecewise continuous with $\mathcal{D}_1 = \{v \in \mathbb{R} : v < 0\}$ and $\mathcal{D}_2 = \{v \in \mathbb{R} : v > 0\}$. Note that the restriction of the vector field to \mathcal{D}_1 can be continuously extended to $\overline{\mathcal{D}_1}$ by setting $X|_{\overline{\mathcal{D}_1}}(0) = g(\sin \theta + \nu \cos \theta)$. Likewise, the restriction of the vector field to \mathcal{D}_2 can be continuously extended to $\overline{\mathcal{D}_2}$ by setting $X|_{\overline{\mathcal{D}_2}}(0) = g(\sin \theta - \nu \cos \theta)$. Therefore, the associated Filippov set-valued map $F[X] : \mathbb{R} \rightarrow \mathfrak{B}(\mathbb{R})$ is given by

$$F[X](v) = \begin{cases} \{g(\sin \theta - \nu \cos \theta)\}, & v > 0, \\ \{g(\sin \theta - d \nu \cos \theta) : d \in [-1, 1]\}, & v = 0, \\ \{g(\sin \theta + \nu \cos \theta)\}, & v < 0, \end{cases}$$

which is singleton-valued for all $v \notin S_X = \{0\}$, and a closed segment at $v = 0$. If the friction coefficient ν is large enough, that is, satisfies $\nu > \tan \theta$, then $F[x](v) < 0$ if $v > 0$ and $F[x](v) > 0$ if $v < 0$. Therefore, the Filippov solutions that start with an initial positive velocity v eventually reach $v = 0$ and remain at 0. This fact precisely corresponds to the observed physical motions for Example 2, where the brick slides for a while and then remains stopped. This example shows that Filippov solutions have physical significance.

The vector field $X : \mathbb{R}^2 \rightarrow \mathbb{R}^2$ for the nonsmooth harmonic oscillator in Example 3 is continuous

on each of the half planes $\{\mathcal{D}_1, \mathcal{D}_2\}$, with

$$\begin{aligned}\mathcal{D}_1 &= \{(x_1, x_2) \in \mathbb{R}^2 : x_1 < 0\}, \\ \mathcal{D}_2 &= \{(x_1, x_2) \in \mathbb{R}^2 : x_1 > 0\},\end{aligned}$$

and discontinuous on $S_X = \{(0, x_2) : x_2 \in \mathbb{R}\}$. Therefore, X is piecewise continuous. Its Filippov set-valued map $F[X] : \mathbb{R}^2 \rightarrow \mathfrak{B}(\mathbb{R}^2)$ is given by

$$F[X](x_1, x_2) = \begin{cases} \{(x_2, -\text{sign}(x_1))\}, & x_1 \neq 0, \\ \{x_2\} \times [-1, 1], & x_1 = 0. \end{cases}$$

Therefore, the closed level sets depicted in Figure 3(b), when traversed clockwise, are Filippov solutions.

The discontinuous vector field $X : [-1, 1]^2 \rightarrow \mathbb{R}^2$ for one agent moving in the square $[-1, 1]^2 \subset \mathbb{R}^2$ under the move-away-from-nearest-neighbor interaction law described in Example 4 is piecewise continuous, with

$$\begin{aligned}\mathcal{D}_1 &= \{(x_1, x_2) \in [-1, 1]^2 : -x_1 < x_2 < x_1\}, \\ \mathcal{D}_2 &= \{(x_1, x_2) \in [-1, 1]^2 : x_2 < x_1 < -x_2\}, \\ \mathcal{D}_3 &= \{(x_1, x_2) \in [-1, 1]^2 : x_1 < x_2 < -x_1\}, \\ \mathcal{D}_4 &= \{(x_1, x_2) \in [-1, 1]^2 : -x_2 < x_1 < x_2\}.\end{aligned}$$

Its Filippov set-valued map, described in (22), maps points outside the diagonals $S_X = \{(a, \pm a) \in [-1, 1]^2 : a \in [-1, 1]\}$ to singletons, maps points in $S_X \setminus \{(0, 0)\}$ to closed segments, and maps $(0, 0)$ to a square polygon. Several Filippov solutions starting from various initial conditions are plotted in Figure 6(b). ■

Let us now discuss what happens on the points of discontinuity of the vector field $X : \mathbb{R}^d \rightarrow \mathbb{R}^d$. Suppose that $x \in S_X$ belongs to just two boundary sets, that is, $x \in \text{bdry}(\mathcal{D}_i) \cap \text{bdry}(\mathcal{D}_j)$, for some distinct $i, j \in \{1, \dots, m\}$, but $x \notin \text{bdry}(\mathcal{D}_k)$, for $k \in \{1, \dots, m\} \setminus \{i, j\}$. In this case,

$$F[X](x) = \text{co}\{X|_{\overline{\mathcal{D}_i}}(x), X|_{\overline{\mathcal{D}_j}}(x)\}.$$

We consider three possibilities. First, if all of the vectors belonging to $F[X](x)$ point into \mathcal{D}_i , then a Filippov solution that reaches S_X at x continues its motion in \mathcal{D}_i (see Figure 8(a)). Likewise, if all of the vectors belonging to $F[X](x)$ point into \mathcal{D}_j , then a Filippov solution that reaches S_X at x continues its motion in \mathcal{D}_j (see Figure 8(b)). Finally, if a vector belonging to $F[X](x)$ is tangent to S_X , then either all Filippov solutions that start at x leave S_X immediately (see Figure 8(c)), or there exist Filippov solutions that reach the set S_X at x , and *remain* in S_X afterward (see Figure 8(d)).

The last kind of trajectories are called *sliding motions*, since they slide along the boundaries of the sets where the vector field is continuous. This type of behavior is illustrated for Example 4 in (23). Sliding motions can also occur along points belonging to the intersection of more than two sets in $\overline{\mathcal{D}_1}, \dots, \overline{\mathcal{D}_m}$. The theory of sliding mode control builds on the existence of this type

of trajectories to design stabilizing feedback controllers. These controllers induce sliding surfaces with the desired properties so that the closed-loop system is stable [6, 7].

The solutions of piecewise continuous vector fields appear frequently in state-dependent switching dynamical systems [37, 38]. Consider, for instance, the case of two dynamical systems with the same unstable equilibrium. By identifying an appropriate switching surface between the two systems, it is often possible to synthesize a discontinuous dynamical system for which the equilibrium is stable.

Uniqueness of Filippov solutions

A discontinuous dynamical system does not necessarily have a unique Filippov solution starting from each initial condition. The situation depicted in Figure 8(c) is a qualitative example in which multiple Filippov solutions exist for the same initial condition. The following is another example of lack of uniqueness.

Example 11: Vector field with nonunique Filippov solutions

Consider the vector field $X : \mathbb{R} \rightarrow \mathbb{R}$ defined by $X(x) = \text{sign}(x)$. For all $x_0 \in \mathbb{R} \setminus \{0\}$, the system (10) has a unique Filippov solution starting from x_0 . However, the system (10) has three maximal solutions $x_1, x_2, x_3 : [0, \infty) \rightarrow \mathbb{R}$ starting from $x_0 = 0$ given by $x_1(t) = -t$, $x_2(t) = 0$, and $x_3(t) = t$. ■

We now provide two complementary uniqueness results for Filippov solutions. The first result [18] considers the Filippov set-valued map associated with a discontinuous vector field, and identifies conditions under which Proposition S2 in “Caratheodory Solutions of Differential Inclusions” can be applied to the resulting differential inclusion. In order to state this result, we need to introduce the following definition. The vector field $X : \mathbb{R}^d \rightarrow \mathbb{R}^d$ is *essentially one-sided Lipschitz* on $U \subset \mathbb{R}^d$ if there exists $L > 0$ such that, for almost all $y, y' \in U$,

$$[X(y) - X(y')]^T (y - y') \leq L \|y - y'\|_2^2. \quad (32)$$

The first uniqueness result for Filippov solutions is stated next.

Proposition 4. *Let $X : \mathbb{R}^d \rightarrow \mathbb{R}^d$ be measurable and locally essentially bounded. Assume that, for all $x \in \mathbb{R}^d$, there exists $\varepsilon > 0$ such that X is essentially one-sided Lipschitz on $B(x, \varepsilon)$. Then, for all $x_0 \in \mathbb{R}^d$, there exists a unique Filippov solution of (10) with initial condition $x(0) = x_0$.*

Note the parallelism of this result with Proposition 2 for ordinary differential equations with a continuous vector field X . Let us apply Proposition 4 to an example.

Example 12: Vector field with unique Filippov solutions

Let \mathbb{Q} denote the set of rational numbers, and define the vector field $X : \mathbb{R} \rightarrow \mathbb{R}$ by

$$X(x) = \begin{cases} 1, & x \in \mathbb{Q}, \\ -1, & x \notin \mathbb{Q}, \end{cases}$$

which is discontinuous everywhere on \mathbb{R} . Since \mathbb{Q} has measure zero in \mathbb{R} , the value of the vector field at rational points plays no role in the computation of $F[X]$. Hence, the associated Filippov set-valued map $F[X] : \mathbb{R} \rightarrow \mathfrak{B}(\mathbb{R})$ is $F[X](x) = \{-1\}$. Since (32) holds for all $y, y' \notin \mathbb{Q}$, there exists a unique solution starting from each initial condition, more precisely, $x : [0, \infty) \rightarrow \mathbb{R}$, where $x(t) = x(0) - t$. ■

The hypotheses of Proposition 4 are somewhat restrictive. This assertion is justified by the observation that, for $d > 1$, piecewise continuous vector fields on \mathbb{R}^d are not essentially one-sided Lipschitz. We justify this assertion in “Uniqueness of Filippov Solutions of Piecewise Continuous Vector Fields.” Figure S2 shows an example of a piecewise continuous vector field with unique solutions starting from each initial condition. However, this uniqueness cannot be guaranteed by means of Proposition 4.

The following result [18] identifies sufficient conditions for uniqueness specifically tailored for piecewise continuous vector fields.

Proposition 5. *Let $X : \mathbb{R}^d \rightarrow \mathbb{R}^d$ be a piecewise continuous vector field, with $\mathbb{R}^d = \mathcal{D}_1 \cup \mathcal{D}_2$. Let $S_X = \text{bdry}(\mathcal{D}_1) = \text{bdry}(\mathcal{D}_2)$ be the set of points at which X is discontinuous, and assume that S_X is a C^2 -manifold. Furthermore, assume that, for $i \in \{1, 2\}$, $X|_{\overline{\mathcal{D}_i}}$ is continuously differentiable on \mathcal{D}_i and $X|_{\overline{\mathcal{D}_1}} - X|_{\overline{\mathcal{D}_2}}$ is continuously differentiable on S_X . If, for each $x \in S_X$, either $X|_{\overline{\mathcal{D}_1}}(x)$ points into \mathcal{D}_2 or $X|_{\overline{\mathcal{D}_2}}(x)$ points into \mathcal{D}_1 , then there exists a unique Filippov solution of (10) starting from each initial condition.*

Note that the continuous differentiability hypothesis on X already guarantees uniqueness of solutions on each of the sets \mathcal{D}_1 and \mathcal{D}_2 . Roughly speaking, the additional assumptions on X along S_X in Proposition 5 guarantee that uniqueness on \mathbb{R}^d is not disrupted by the discontinuities. Under the stated assumptions, when reaching S_X , Filippov solutions can cross it or slide along it. The situation depicted in Figure 8(c) is thus ruled out.

Examples 2-4 revisited: Unique Filippov solutions for the sliding brick, the nonsmooth harmonic oscillator, and the move-away-from-nearest-neighbor interaction law

As an application of Proposition 5, let us reconsider Example 2. At $v = 0$, the vector $X|_{\overline{\mathcal{D}_1}}(0)$ points into \mathcal{D}_2 , see Figure 2(b). Proposition 5 then ensures that there exists a unique Filippov solution starting from each initial condition.

For Example 3, the vector $X|_{\overline{\mathcal{D}_1}}$ points into \mathcal{D}_2 at every point in $S_X \cap \{x_2 > 0\}$, while the vector $X|_{\overline{\mathcal{D}_2}}$ points into \mathcal{D}_1 at every point in $S_X \cap \{x_2 < 0\}$, see Figure 3(a). Moreover, there is only one

solution (the equilibrium solution) starting from $(0, 0)$. Therefore, using Proposition 5, we conclude that this system has a unique Filippov solution starting from each initial condition.

For Example 4, it is convenient to define $\mathcal{D}_5 = \mathcal{D}_1$. Then, at $(x_1, x_2) \in \text{bdry}(\mathcal{D}_i) \cap \text{bdry}(\mathcal{D}_{i+1}) \setminus \{(0, 0)\}$, with $i \in \{1, \dots, 4\}$, the vector $X_{|\overline{\mathcal{D}_i}}(x_1, x_2)$ points into \mathcal{D}_{i+1} , and the vector $X_{|\overline{\mathcal{D}_{i+1}}}(x_1, x_2)$ points into \mathcal{D}_i , see Figure 6(a). Moreover, there is only one solution (the equilibrium solution) starting from $(0, 0)$. Therefore, using Proposition 5, we conclude that Example 4 has a unique Filippov solution starting from each initial condition. ■

Proposition 5 can also be applied to piecewise continuous vector fields with an arbitrary number of partitioning domains, provided that the set where the vector field is discontinuous is a disjoint union of surfaces resulting from pairwise intersections of the boundaries of pairs of domains. Alternative versions of this result can also be stated for time-varying piecewise continuous vector fields, as well as for situations in which more than two domains intersect at a point of discontinuity [18, Theorem 4 at page 115].

The literature contains additional results guaranteeing uniqueness of Filippov solutions tailored to specific classes of dynamical systems. For instance, [39] studies uniqueness for relay linear systems, [11] investigates uniqueness for adaptive control systems, while [40] establishes uniqueness for a class of discontinuous differential equations whose vector field depends on the solution of a scalar conservation law.

Solutions of control systems with discontinuous inputs

Let $X : \mathbb{R}^d \times \mathcal{U} \rightarrow \mathbb{R}^d$, where $\mathcal{U} \subseteq \mathbb{R}^m$ is the set of allowable control-function values, and consider the control equation on \mathbb{R}^d given by

$$\dot{x}(t) = X(x(t), u(t)). \quad (33)$$

At first sight, a natural way to identify a notion of solution for (33) is to select a control input, either an open-loop $u : [0, \infty) \rightarrow \mathcal{U}$, a closed-loop $u : \mathbb{R}^d \rightarrow \mathcal{U}$, or a combination $u : [0, \infty) \times \mathbb{R}^d \rightarrow \mathcal{U}$, and then consider the resulting differential equation. When the selected control input u is a discontinuous function of $x \in \mathbb{R}^d$, then we can consider the solution notions of Caratheodory or Filippov. At least two alternatives are considered in the literature. We discuss them next.

Solutions by means of differential inclusions

A first alternative to defining a solution notion consists of associating a differential inclusion with the control equation (33). In this approach, the set-valued map $G[X] : \mathbb{R}^d \rightarrow \mathfrak{B}(\mathbb{R}^d)$ is defined by

$$G[X](x) \triangleq \{X(x, u) : u \in \mathcal{U}\}. \quad (34)$$

In other words, the set $G[X](x)$ captures all of the directions in \mathbb{R}^d that can be generated at x with controls belonging to \mathcal{U} . Consider now the differential inclusion

$$\dot{x}(t) \in G[X](x(t)). \quad (35)$$

A *solution of (33)* on $[0, t_1] \subset \mathbb{R}$ is defined to be a Caratheodory solution of the differential inclusion (35), that is, an absolutely continuous map $x : [0, t_1] \rightarrow \mathbb{R}^d$ such that $\dot{x}(t) \in G[X](x(t))$ for almost all $t \in [0, t_1]$.

If we choose an open-loop input $u : [0, \infty) \rightarrow \mathcal{U}$ in (33), then a Caratheodory solution of the resulting dynamical system is also a Caratheodory solution of the differential inclusion (35). Alternatively, it can be shown [18] that, if X is continuous and \mathcal{U} is compact, then the converse is also true. The differential inclusion (35) has the advantage of not focusing attention on a particular control input, but rather allows us to comprehensively study and understand the properties of the control system.

Sample-and-hold solutions

A second alternative to defining a solution notion for the control equation (33) uses the notion of sample-and-hold solution [41]. As discussed in the section “Stabilization of control systems,” this notion plays a key role in the stabilization of asymptotically controllable systems.

A *partition* of the interval $[t_0, t_1]$ is an increasing sequence $\pi = \{s_i\}_{i=0}^N$ with $s_0 = t_0$ and $s_N = t_1$. The partition need not be finite. The notion of a partition of $[t_0, \infty)$ is defined similarly. The diameter of π is $\text{diam}(\pi) \triangleq \sup\{s_i - s_{i-1} : i \in \{1, \dots, N\}\}$. Given a control input $u : [0, \infty) \times \mathbb{R}^d \rightarrow \mathcal{U}$, an initial condition x_0 , and a partition π of $[0, t_1]$, a π -*solution of (33)* defined on $[0, t_1] \subset \mathbb{R}$ is the map $x : [0, t_1] \rightarrow \mathbb{R}^d$, with $x(0) = x_0$, recursively defined by requiring the curve $t \in [s_{i-1}, s_i] \mapsto x(t)$, for $i \in \{1, \dots, N - 1\}$, to be a Caratheodory solution of the differential equation

$$\dot{x}(t) = X(x(t), u(s_{i-1}, x(s_{i-1}))). \quad (36)$$

π -solutions are also referred to as *sample-and-hold* solutions because the control is held fixed throughout each interval of the partition at the value according to the state at the beginning of the interval. Figure 7 shows an example of a π -solution. The existence of π -solutions is guaranteed [24] if, for all $u \in \mathcal{U} \subseteq \mathbb{R}^m$, the map $x \mapsto X(x, u)$ is continuous.

Nonsmooth Analysis

We now consider candidate nonsmooth Lyapunov functions for discontinuous differential equations. The level of generality provided by nonsmooth analysis is not always necessary. The stability properties of some discontinuous dynamical systems and differential inclusions can be analyzed with smooth functions, as the following example shows.

Examples 5 and 6 revisited: Stability of the origin for the sign function

We have already established that the vector fields (11) and (12) in examples 5 and 6, respectively, have unique Filippov solutions starting from each initial condition. Now, consider the smooth

Lyapunov function $f : \mathbb{R} \rightarrow \mathbb{R}$, where $f(x) = x^2/2$. Now, for all $x \neq 0$, we have

$$\nabla f(x) \cdot X(x) = -|x| < 0.$$

Since, according to (20), $F[X](x) = \{X(x)\}$ on $\mathbb{R} \setminus \{0\}$, we deduce that the function f is decreasing along every Filippov solution of (11) and (12) that starts on $\mathbb{R} \setminus \{0\}$. Therefore, we conclude that the equilibrium $x = 0$ is globally asymptotically stable. ■

However, nonsmooth Lyapunov functions may be needed if dealing with discontinuous dynamics, as the following example shows.

Example 3 revisited: The nonsmooth harmonic oscillator does not admit a smooth Lyapunov function

Consider the vector field for the nonsmooth harmonic oscillator in Example 3. We reason as in [16]. As stated in the section “Piecewise continuous vector fields and sliding motions,” all of the Filippov solutions of (3) are periodic, and correspond to the curves plotted in Figure 3(b). Therefore, if a smooth Lyapunov function $f : \mathbb{R}^2 \rightarrow \mathbb{R}$ exists, then it must be constant on each Filippov solution. Since the level sets of f must be one-dimensional, it follows that each curve must be a level set. This property contradicts the fact that the function is smooth, since the level sets of a smooth function are also smooth, and the Filippov solutions plotted in Figure 3(b) are not smooth along the x_2 -coordinate axis. ■

The above example illustrates the need to consider nonsmooth analysis. Similar examples can be found in [14, Section 2.2.2]. It is also worth noting that the presentation in “Stability analysis by means of the generalized gradient of a nonsmooth Lyapunov function” boils down to classical stability analysis when the candidate Lyapunov function is smooth.

In this section we discuss two tools from nonsmooth analysis, namely, the generalized gradient and the proximal subdifferential [9, 24]. As with the notions of solution of discontinuous differential equations, multiple generalized derivative notions are available in the literature when a function fails to be differentiable. These notions include, in addition to the two considered in this section, the generalized (super or sub) differential, the (upper or lower, right or left) Dini derivative, and the contingent derivative [19, 24, 42, 43]. Here, we focus on the notions of the generalized gradient and proximal subdifferential because of their role in providing stability tools for discontinuous differential equations.

The generalized gradient of a locally Lipschitz function

Rademacher’s theorem [9] states that every locally Lipschitz function is differentiable almost everywhere in the sense of Lebesgue measure. When considering a locally Lipschitz function as a candidate Lyapunov function, this statement may raise the question of whether to disregard those points where the gradient does not exist. Conceivably, the solutions of the dynamical system stay for almost all time away from “bad” points where no gradient of the function exists. However, this assumption is not always valid. As we show in Example 16 below, the solutions of a dynamical

system may insist on staying on the “bad” points forever. In that case, having some gradient-like information is helpful.

Let $f : \mathbb{R}^d \rightarrow \mathbb{R}$ be a locally Lipschitz function, and let $\Omega_f \subset \mathbb{R}^d$ denote the set of points where f fails to be differentiable. The *generalized gradient* $\partial f : \mathbb{R}^d \rightarrow \mathfrak{B}(\mathbb{R}^d)$ of f is defined by

$$\partial f(x) \triangleq \text{co}\left\{\lim_{i \rightarrow \infty} \nabla f(x_i) : x_i \rightarrow x, x_i \notin S \cup \Omega_f\right\}, \quad (37)$$

where co denotes convex hull. In this definition, $S \subset \mathbb{R}^d$ is a set of measure zero that can be arbitrarily chosen to simplify the computation. The resulting set $\partial f(x)$ is independent of the choice of S . From the definition, the generalized gradient of f at x consists of all convex combinations of all of the possible limits of the gradient at neighboring points where f is differentiable. Equivalent definitions of the generalized gradient are given in [9].

Some useful properties of the generalized gradient are summarized in the following result [24].

Proposition 6. *If $f : \mathbb{R}^d \rightarrow \mathbb{R}$ is locally Lipschitz at $x \in \mathbb{R}^d$, then the following statements hold:*

- (i) $\partial f(x)$ is nonempty, compact, and convex.
- (ii) The set-valued map $\partial f : \mathbb{R}^d \rightarrow \mathfrak{B}(\mathbb{R}^d)$, $x \mapsto \partial f(x)$, is upper semicontinuous and locally bounded at x .
- (iii) If f is continuously differentiable at x , then $\partial f(x) = \{\nabla f(x)\}$.

Let us compute the generalized gradient for an illustrative example.

Example 13: Generalized gradient of the absolute value function

Consider the locally Lipschitz function $f : \mathbb{R} \rightarrow \mathbb{R}$, where $f(x) = |x|$, which is continuously differentiable everywhere except at 0. Since $\nabla f(x) = 1$ for $x > 0$ and $\nabla f(x) = -1$ for $x < 0$, from (37), we deduce

$$\partial f(0) = \text{co}\{1, -1\} = [-1, 1],$$

while, by Proposition 6(iii), we deduce $\partial f(x) = \{1\}$ for $x > 0$ and $\partial f(x) = \{-1\}$ for $x < 0$. ■

The next example shows that Proposition 6(iii) may not be true if f is not continuously differentiable.

Example 14: Generalized gradient of a differentiable but not continuously differentiable function

Consider the locally Lipschitz function $f : \mathbb{R} \rightarrow \mathbb{R}$, where $f(x) = x^2 \sin(\frac{1}{x})$, which is continuously differentiable everywhere except at 0, where it is only differentiable. It can be shown that $\nabla f(0) = 0$,

while $\nabla f(x) = 2x \sin(\frac{1}{x}) - \cos(\frac{1}{x})$ for $x \neq 0$. From (37), we deduce that $\partial f(0) = [-1, 1]$, which is different from $\{\nabla f(0)\} = \{0\}$. This example illustrates that Proposition 6(iii) may not be valid if f is not continuously differentiable at the point x . ■

Computing the generalized gradient

Computation of the generalized gradient of a locally Lipschitz function is often a difficult task. In addition to the brute force approach of working from the definition (37), various results are available to facilitate this computation. Many results that are valid for ordinary derivatives have a counterpart in this setting. We summarize some of these results here, and refer the reader to [9, 24] for a complete exposition. In the statements of these results, the notion of a regular function plays a prominent role, see “Regular Functions” for a precise definition.

Dilation rule. If $f : \mathbb{R}^d \rightarrow \mathbb{R}$ is locally Lipschitz at $x \in \mathbb{R}^d$ and $s \in \mathbb{R}$, then the function sf is locally Lipschitz at x , and

$$\partial(sf)(x) = s \partial f(x). \quad (38)$$

Sum rule. If $f_1, f_2 : \mathbb{R}^d \rightarrow \mathbb{R}$ are locally Lipschitz at $x \in \mathbb{R}^d$ and $s_1, s_2 \in \mathbb{R}$, then the function $s_1 f_1 + s_2 f_2$ is locally Lipschitz at x , and

$$\partial(s_1 f_1 + s_2 f_2)(x) \subseteq s_1 \partial f_1(x) + s_2 \partial f_2(x), \quad (39)$$

where the sum of two sets A_1 and A_2 is defined as $A_1 + A_2 = \{a_1 + a_2 : a_1 \in A_1, a_2 \in A_2\}$. Moreover, if f_1 and f_2 are regular at x , and $s_1, s_2 \in [0, \infty)$, then equality holds and $s_1 f_1 + s_2 f_2$ is regular at x .

Product rule. If $f_1, f_2 : \mathbb{R}^d \rightarrow \mathbb{R}$ are locally Lipschitz at $x \in \mathbb{R}^d$, then the function $f_1 f_2$ is locally Lipschitz at x , and

$$\partial(f_1 f_2)(x) \subseteq f_2(x) \partial f_1(x) + f_1(x) \partial f_2(x). \quad (40)$$

Moreover, if f_1 and f_2 are regular at x , and $f_1(x), f_2(x) \geq 0$, then equality holds and $f_1 f_2$ is regular at x .

Quotient rule. If $f_1, f_2 : \mathbb{R}^d \rightarrow \mathbb{R}$ are locally Lipschitz at $x \in \mathbb{R}^d$, and $f_2(x) \neq 0$, then the function f_1/f_2 is locally Lipschitz at x , and

$$\partial\left(\frac{f_1}{f_2}\right)(x) \subseteq \frac{1}{f_2^2(x)} \left(f_2(x) \partial f_1(x) - f_1(x) \partial f_2(x) \right). \quad (41)$$

Moreover, if f_1 and $-f_2$ are regular at x , and $f_1(x) \geq 0$ and $f_2(x) > 0$, then equality holds and f_1/f_2 is regular at x .

Chain rule. If each component of $h : \mathbb{R}^d \rightarrow \mathbb{R}^m$ is locally Lipschitz at $x \in \mathbb{R}^d$ and $g : \mathbb{R}^m \rightarrow \mathbb{R}$ is locally Lipschitz at $h(x) \in \mathbb{R}^m$, then the function $g \circ h$ is locally Lipschitz at x , and

$$\partial(g \circ h)(x) \subseteq \text{co} \left\{ \sum_{k=1}^m \alpha_k \zeta_k : (\alpha_1, \dots, \alpha_m) \in \partial g(h(x)), (\zeta_1, \dots, \zeta_m) \in \partial h_1(x) \times \dots \times \partial h_m(x) \right\}. \quad (42)$$

Moreover, if g is regular at $h(x)$, each component of h is regular at x , and $\partial g(h(x)) \subset [0, \infty)^m$, then equality holds and $g \circ h$ is regular at x .

The following useful result from [9, Proposition 2.3.12] concerns the generalized gradient of the maximum and the minimum of a finite set of functions.

Proposition 7. *For $k \in \{1, \dots, m\}$, let $f_k : \mathbb{R}^d \rightarrow \mathbb{R}$ be locally Lipschitz at $x \in \mathbb{R}^d$, and define the functions $f_{\max}, f_{\min} : \mathbb{R}^d \rightarrow \mathbb{R}$ by*

$$\begin{aligned} f_{\max}(y) &\triangleq \max\{f_k(y) : k \in \{1, \dots, m\}\}, \\ f_{\min}(y) &\triangleq \min\{f_k(y) : k \in \{1, \dots, m\}\}. \end{aligned}$$

Then, the following statements hold:

(i) f_{\max} and f_{\min} are locally Lipschitz at x .

(ii) Let $I_{\max}(x)$ denote the set of indices k for which $f_k(x) = f_{\max}(x)$. Then

$$\partial f_{\max}(x) \subseteq \text{co} \bigcup \{\partial f_i(x) : i \in I_{\max}(x)\}. \quad (43)$$

Furthermore, if f_i is regular at x for all $i \in I_{\max}(x)$, then equality holds and f_{\max} is regular at x ,

(iii) Let $I_{\min}(x)$ denote the set of indices k for which $f_k(x) = f_{\min}(x)$. Then

$$\partial f_{\min}(x) \subseteq \text{co} \bigcup \{\partial f_i(x) : i \in I_{\min}(x)\}. \quad (44)$$

Furthermore, if $-f_i$ is regular at x for all $i \in I_{\min}(x)$, then equality holds and $-f_{\min}$ is regular at x .

It follows from Proposition 7 that the maximum of a finite set of continuously differentiable functions is a locally Lipschitz and regular function whose generalized gradient at each point x is easily computable as the convex hull of the gradients of the functions that attain the maximum at x .

Example 13 revisited: Generalized gradient of the absolute value function

The absolute value function $f(x) = |x|$ can be rewritten as $f(x) = \max\{x, -x\}$. Both $x \mapsto x$ and $x \mapsto -x$ are continuously differentiable, and hence locally Lipschitz and regular. Therefore, according to Proposition 7 (i) and (ii), f is locally Lipschitz and regular, and its generalized gradient is

$$\partial f(x) = \begin{cases} \{1\}, & x > 0, \\ [-1, 1], & x = 0, \\ \{-1\}, & x < 0. \end{cases} \quad (45)$$

This result is obtained in Example 13 by direct computation. ■

Example 15: Generalized gradient of the minus absolute value function

The minimum of a finite set of regular functions is not always regular. A simple example is given by $g(x) = \min\{x, -x\} = -|x|$, which is not regular at 0, as we show in “Regular Functions.” However, according to Proposition 7(iii), this fact does not mean that its generalized gradient cannot be computed. Indeed,

$$\partial g(x) = \begin{cases} \{-1\}, & x > 0, \\ [-1, 1], & x = 0, \\ \{1\}, & x < 0. \end{cases} \quad (46)$$

This result can also be obtained by combining (45) with the application of the dilation rule (38) to the function $f(x) = |x|$ with the parameter $s = -1$. ■

Critical points and directions of descent

A *critical* point of $f : \mathbb{R}^d \rightarrow \mathbb{R}$ is a point $x \in \mathbb{R}^d$ such that $0 \in \partial f(x)$. According to this definition, the maximizers and minimizers of a locally Lipschitz function are critical points. As an example, $x = 0$ is the unique minimizer of $f(x) = |x|$, and, indeed, we see that $0 \in \partial f(0)$ in (45).

If a function f is continuously differentiable, then the gradient ∇f provides the direction of maximum ascent of f (respectively, $-\nabla f$ provides the direction of maximum descent of f). When we consider a locally Lipschitz function, however, the question of choosing the directions of descent among all of the available directions in the generalized gradient arises. Without loss of generality, we restrict our discussion to directions of descent, since a direction of descent of $-f$ corresponds to a direction of ascent of f , while f is locally Lipschitz if and only if $-f$ is locally Lipschitz.

Let $\text{Ln} : \mathfrak{B}(\mathbb{R}^d) \rightarrow \mathfrak{B}(\mathbb{R}^d)$ be the set-valued map that associates to each subset S of \mathbb{R}^d the set of least-norm elements of its closure \overline{S} . If the set S is convex and closed, then the set $\text{Ln}(S)$ is a singleton, which consists of the orthogonal projection of 0 onto S . For a locally Lipschitz function f , consider the *generalized gradient vector field* $\text{Ln}(\partial f) : \mathbb{R}^d \rightarrow \mathbb{R}^d$ defined by

$$x \mapsto \text{Ln}(\partial f)(x) \triangleq \text{Ln}(\partial f(x)).$$

It turns out that $-\text{Ln}(\partial f)(x)$ is a direction of descent of f at $x \in \mathbb{R}^d$. More precisely [9], if $0 \notin \partial f(x)$, then there exists $T > 0$ such that

$$f(x - t \text{Ln}(\partial f)(x)) \leq f(x) - \frac{t}{2} \|\text{Ln}(\partial f)(x)\|_2^2 < f(x), \quad 0 < t < T, \quad (47)$$

that is, by taking a small step in the direction $-\text{Ln}(\partial f)(x)$, the function f is guaranteed to decrease by an amount that scales linearly with the stepsize.

Example 16: Minimum-distance-to-polygonal-boundary function

Let $Q \subset \mathbb{R}^2$ be a convex polygon. Consider the minimum distance function $\text{sm}_Q : Q \rightarrow \mathbb{R}$ from a point within the polygon to its boundary defined by

$$\text{sm}_Q(p) \triangleq \min\{\|p - q\|_2 : q \in \text{bdry}(Q)\}.$$

Note that the value of sm_Q at p is the radius of the largest disk with center p contained in the polygon. Moreover, the function sm_Q is locally Lipschitz on Q . To show this, rewrite sm_Q as

$$\text{sm}_Q(p) \triangleq \min\{\text{dist}(p, e) : e \text{ is an edge of } Q\},$$

where $\text{dist}(p, e)$ denotes the Euclidean distance from the point p to the edge e . Indeed, the function sm_Q is concave on Q .

Let us consider the generalized gradient vector field corresponding to sm_Q , where the definition of sm_Q is extended outside Q by setting $\text{sm}_Q(p) = -\min\{\|p - q\|_2 : q \in \text{bdry}(Q)\}$ for $p \notin Q$. Applying Proposition 7(iii), we deduce that $-\text{sm}_Q$ is regular on Q and its generalized gradient at $p \in Q$ is

$$\partial \text{sm}_Q(p) = \text{co}\{n_e : e \text{ edge of } Q \text{ such that } \text{sm}_Q(p) = \text{dist}(p, e)\},$$

where n_e denotes the unit normal to the edge e pointing toward the interior of Q . Therefore, at points p in Q for which there exists a unique edge e of Q nearest to p , the function sm_Q is differentiable, and its generalized gradient vector field is given by $\text{Ln}(\text{sm}_Q)(p) = n_e$. Note that this vector field corresponds to the move-away-from-nearest-neighbor interaction law for one agent moving in the polygon introduced in Example 4!

At points p of Q where various edges $\{e_1, \dots, e_m\}$ are at the same minimum distance to p , the function sm_Q is not differentiable, and its generalized gradient vector field is given by the least-norm element in $\text{co}\{n_{e_1}, \dots, n_{e_m}\}$. If p is not a critical point, 0 does not belong to $\text{co}\{n_{e_1}, \dots, n_{e_m}\}$, and the least-norm element points in the direction of the bisector line between two of the edges in $\{e_1, \dots, e_m\}$. Figure 9 shows a plot of the generalized gradient vector field of sm_Q on the square $Q = [-1, 1]^2$. Note the similarity with the plot in Figure 6(a). Indeed, the critical points of sm_Q are characterized [44] by the statement that $0 \in \partial \text{sm}_Q(p)$ if and only if p belongs to the incenter set of Q .

The incenter set of Q is composed of the centers of the largest-radius disks contained in Q . In general, the incenter set is a segment (consider the example of a rectangle). However, if $0 \in \text{interior}(\partial \text{sm}_Q(p))$, then the incenter set of Q is the singleton $\{p\}$. ■

Nonsmooth gradient flows

Given a locally Lipschitz function $f : \mathbb{R}^d \rightarrow \mathbb{R}$, the nonsmooth analog of the classical gradient descent flow of a differentiable function is defined by

$$\dot{x}(t) = -\text{Ln}(\partial f)(x(t)). \tag{48}$$

According to (47), unless the flow is already at a critical point, $-\text{Ln}(\partial f)(x)$ is a direction of descent of f at x . Since this nonsmooth gradient vector field is discontinuous, we have to specify a notion of solution for (48). In this case, we use the notion of Filippov solution due largely to the remarkable fact [36] that the Filippov set-valued map associated with the nonsmooth gradient flow of f given by (48) is precisely the generalized gradient of the function, as the next result states.

Proposition 8 (Filippov set-valued map of nonsmooth gradient). *If $f : \mathbb{R}^d \rightarrow \mathbb{R}$ is locally Lipschitz, then the Filippov set-valued map $F[\text{Ln}(\partial f)] : \mathbb{R}^d \rightarrow \mathfrak{B}(\mathbb{R}^d)$ of the nonsmooth gradient of f is equal to the generalized gradient $\partial f : \mathbb{R}^d \rightarrow \mathfrak{B}(\mathbb{R}^d)$ of f , that is, for $x \in \mathbb{R}^d$,*

$$F[\text{Ln}(\partial f)](x) = \partial f(x). \quad (49)$$

As a consequence of Proposition 8, the discontinuous system (48) is equivalent to the differential inclusion

$$\dot{x}(t) \in -\partial f(x(t)). \quad (50)$$

Solutions of (48) are sometimes called “slow motions” of the differential inclusion because of the use of the least-norm operator, which selects the vector in the generalized gradient of the function with the smallest magnitude. How can we analyze the asymptotic behavior of the solutions of this system? If the function f is differentiable, then the invariance principle allows us to deduce that, for functions with bounded level sets, the solutions of the gradient flow converge to the set of critical points. The key tool behind this result is to establish that the function decreases along solutions of the system. This behavior is formally expressed through the notion of the Lie derivative. In the section “Nonsmooth Stability Analysis” we discuss generalizations of the notion of Lie derivative to the nonsmooth case. These notions allow us to study the asymptotic convergence properties of the trajectories of nonsmooth gradient flows.

The proximal subdifferential of a lower semicontinuous function

A complementary set of nonsmooth analysis tools for dealing with Lyapunov functions arises from the concept of proximal subdifferential. This concept has the advantage of being defined for the class of lower semicontinuous functions, which is larger than the class of locally Lipschitz functions. The generalized gradient provides us with directional descent information, that is, directions along which the function decreases. The price we pay for using the proximal subdifferential is that explicit descent directions are not generally known to us. Nevertheless, the proximal subdifferential allows us to reason about the monotonic properties of the function, which, as we show in the section “Stability analysis by means of the proximal subdifferential of a nonsmooth Lyapunov function,” turn out to be sufficient to provide stability results. The proximal subdifferential is particularly appropriate when dealing with convex functions. Here, we briefly touch on the topic of convex analysis. For further information, see [45, 46, 47].

A function $f : \mathbb{R}^d \rightarrow \mathbb{R}$ is *lower semicontinuous* [24] at $x \in \mathbb{R}^d$ if, for all $\varepsilon \in (0, \infty)$, there exists $\delta \in (0, \infty)$ such that, for $y \in B(x, \delta)$, $f(y) \geq f(x) - \varepsilon$. The *epigraph* of f is the set of points lying on or above its graph, that is, $\text{epi}(f) = \{(x, \mu) \in \mathbb{R}^d \times \mathbb{R} : f(x) \leq \mu\} \subset \mathbb{R}^{d+1}$. The function f

is lower semicontinuous if and only if its epigraph is closed. The function $f : \mathbb{R}^d \rightarrow \mathbb{R}$ is *upper semicontinuous* at $x \in \mathbb{R}^d$ if $-f$ is lower semicontinuous at x . Note that f is continuous at x if and only if f is both upper semicontinuous and lower semicontinuous at x .

For a lower semicontinuous function $f : \mathbb{R}^d \rightarrow \mathbb{R}$, the vector $\zeta \in \mathbb{R}^d$ is a *proximal subgradient* of f at $x \in \mathbb{R}^d$ if there exist $\sigma, \delta \in (0, \infty)$ such that, for all $y \in B(x, \delta)$,

$$f(y) \geq f(x) + \zeta(y - x) - \sigma^2 \|y - x\|_2^2. \quad (51)$$

The set $\partial_P f(x)$ of all proximal subgradients of f at x is the *proximal subdifferential* of f at x . The proximal subdifferential at x , which may be empty, is convex but not necessarily open, closed, or bounded.

Geometrically, the definition of a proximal subgradient can be interpreted as follows. Equation (51) is equivalent to saying that, in a neighborhood of x , the function $y \mapsto f(y)$ majorizes the quadratic function $y \mapsto f(x) + \zeta(y - x) - \sigma^2 \|y - x\|_2^2$. In other words, there exists a parabola that locally fits under the epigraph of f at $(x, f(x))$. This geometric interpretation is useful for explicitly computing the proximal subdifferential, see Figure 10(a) for an illustration. An additional geometric characterization of the proximal subdifferential of f can be given in terms of normal cones and the epigraph of f . Given a closed set $S \subseteq \mathbb{R}^d$ and $x \in S$, the *proximal normal cone* $N_S(x)$ to S is the set of all $y \in \mathbb{R}^d$ such that x is the nearest point in S to $x + \lambda y$, for $\lambda > 0$ sufficiently small. Then, $\zeta \in \partial_P f(x)$ if and only if

$$(\zeta, -1) \in N_{\text{epi}(f)}(x, f(x)). \quad (52)$$

Figure 10(b) illustrates this geometric interpretation.

Example 17: Proximal subdifferentials of the absolute value function and its negative

Consider the locally Lipschitz functions $f, g : \mathbb{R} \rightarrow \mathbb{R}$, $f(x) = |x|$ and $g(x) = -|x|$. Using the geometric interpretation of (51), it can be seen that

$$\partial_P f(x) = \begin{cases} \{1\}, & x < 0, \\ [-1, 1], & x = 0, \\ \{-1\}, & x > 0, \end{cases} \quad (53)$$

$$\partial_P g(x) = \begin{cases} \{-1\}, & x < 0, \\ \emptyset, & x = 0, \\ \{1\}, & x > 0. \end{cases} \quad (54)$$

Note that (53)-(54) is an example of the fact that $\partial_P(-f)$ and $-\partial_P f$ are not necessarily equal. The generalized gradient of g in (46) is different from the proximal subdifferential of g in (54). ■

Unlike the case of the generalized gradient, the proximal subdifferential may not coincide with $\nabla f(x)$ when f is continuously differentiable. The function $f : \mathbb{R} \rightarrow \mathbb{R}$, where $f(x) = -|x|^{3/2}$, is continuously differentiable with $\nabla f(0) = 0$, but $\partial_P f(0) = \emptyset$. In fact, a continuously differentiable

function on \mathbb{R} with an empty proximal subdifferential almost everywhere is provided in [48]. However, the density theorem (cf. [24, Theorem 3.1]) states that the proximal subdifferential of a lower semicontinuous function is nonempty on a dense set of its domain of definition, although a dense set can have zero Lebesgue measure.

On the other hand, the proximal subdifferential can be more useful than the generalized gradient in some situations, as the following example shows.

Example 18: Proximal subdifferential of the square root of the absolute value

Consider the function $f : \mathbb{R} \rightarrow \mathbb{R}$, where $f(x) = \sqrt{|x|}$, which is continuous at 0, but not locally Lipschitz at 0, which is the global minimizer of f . The generalized gradient does not exist at 0, and hence we cannot characterize this point as a critical point. However, the function f is lower semicontinuous with proximal subdifferential,

$$\partial_P f(x) = \begin{cases} \left\{ \frac{1}{2\sqrt{x}} \right\}, & x > 0, \\ \mathbb{R}, & x = 0, \\ \left\{ -\frac{1}{2\sqrt{-x}} \right\}, & x < 0. \end{cases} \quad (55)$$

As we discuss later, it follows from (55) that 0 is the unique global minimizer of f . ■

If $f : \mathbb{R}^d \rightarrow \mathbb{R}$ is locally Lipschitz at $x \in \mathbb{R}^d$, then the proximal subdifferential of f at x is bounded. In general, the relationship between the generalized gradient and the proximal subdifferential of a function f that is locally Lipschitz at $x \in \mathbb{R}^d$ is expressed by

$$\partial f(x) = \text{co} \left\{ \lim_{n \rightarrow \infty} \zeta_n \in \mathbb{R}^d : \zeta_n \in \partial_P f(x_n) \text{ and } \lim_{n \rightarrow \infty} x_n = x \right\}.$$

Computing the proximal subdifferential

As with the generalized gradient, computation of the proximal subdifferential of a lower semicontinuous function is often far from straightforward. Here we provide some useful results following the exposition in [24].

Dilation rule. If $f : \mathbb{R}^d \rightarrow \mathbb{R}$ is lower semicontinuous at $x \in \mathbb{R}^d$ and $s \in (0, \infty)$, then the function sf is lower semicontinuous at x , and

$$\partial_P(sf)(x) = s \partial_P f(x). \quad (56)$$

Sum rule. If $f_1, f_2 : \mathbb{R}^d \rightarrow \mathbb{R}$ are lower semicontinuous at $x \in \mathbb{R}^d$, then the function $f_1 + f_2$ is lower semicontinuous at x , and

$$\partial_P f_1(x) + \partial_P f_2(x) \subseteq \partial_P(f_1 + f_2)(x). \quad (57)$$

Moreover, if either f_1 or f_2 are twice continuously differentiable, then equality holds.

Fuzzy sum rule. If $f_1, f_2 : \mathbb{R}^d \rightarrow \mathbb{R}$ is lower semicontinuous at $x \in \mathbb{R}^d$, $\zeta \in \partial_P(f_1 + f_2)(x)$, and $\varepsilon > 0$, then there exist $x_1, x_2 \in B(x, \varepsilon)$ with $|f_i(x_i) - f_i(x)| < \varepsilon$, $i \in \{1, 2\}$, such that

$$\zeta \in \partial_P f_1(x_1) + \partial_P f_2(x_2) + \varepsilon B(0, 1). \quad (58)$$

Chain rule. Assume that either $h : \mathbb{R}^d \rightarrow \mathbb{R}^m$ linear and $g : \mathbb{R}^m \rightarrow \mathbb{R}$ lower semicontinuous at $h(x) \in \mathbb{R}^m$, or $h : \mathbb{R}^d \rightarrow \mathbb{R}^m$ locally Lipschitz at $x \in \mathbb{R}^d$ and $g : \mathbb{R}^m \rightarrow \mathbb{R}$ locally Lipschitz at $h(x) \in \mathbb{R}^m$. If $\zeta \in \partial_P(g \circ h)(x)$ and $\varepsilon > 0$, then there exist $\tilde{x} \in \mathbb{R}^d$, $\tilde{y} \in \mathbb{R}^m$, and $\gamma \in \partial_P g(\tilde{y})$ with $\max\{\|\tilde{x} - x\|_2, \|\tilde{y} - h(x)\|_2\} < \varepsilon$ such that $\|h(\tilde{x}) - h(x)\|_2 < \varepsilon$ and

$$\zeta \in \partial_P(\gamma^T h)(\tilde{x}) + \varepsilon B(0, 1), \quad (59)$$

where $\gamma^T h : \mathbb{R}^d \rightarrow \mathbb{R}$ is defined by $(\gamma^T h)(x) = \gamma^T h(x)$.

The statement of the chain rule (59) shows a characteristic feature of the proximal subdifferential. That is, rather than at an specific point of interest, the proximal subdifferential can only be expressed with objects evaluated at neighboring points.

Computation of the proximal subdifferential of a twice continuously differentiable function is particularly simple. If $f : \mathbb{R}^d \rightarrow \mathbb{R}$ is twice continuously differentiable on the open set $U \subseteq \mathbb{R}^d$, then, for all $x \in U$,

$$\partial_P f(x) = \{\nabla f(x)\}. \quad (60)$$

This simplicity also works for continuously differentiable convex functions, as the following result [20, 24, 47] states. Note that every convex function on \mathbb{R}^d is locally Lipschitz, and hence continuous.

Proposition 9. *If $f : \mathbb{R}^d \rightarrow \mathbb{R}$ is convex, then the following statements hold:*

- (i) *For $x \in \mathbb{R}^d$, $\zeta \in \partial_P f(x)$ if and only if, for all $y \in \mathbb{R}^d$, $f(y) \geq f(x) + \zeta(y - x)$.*
- (ii) *The set-valued map $\partial_P f : \mathbb{R}^d \rightarrow \mathfrak{B}(\mathbb{R}^d)$, $x \mapsto \partial_P f(x)$, takes nonempty, compact, and convex values, and is upper semicontinuous and locally bounded.*
- (iii) *If, in addition, f is continuously differentiable, then, for all $x \in \mathbb{R}^d$, $\partial_P f(x) = \{\nabla f(x)\}$.*

Example 17 revisited: Proximal subdifferential of the absolute value function

The computation (53) of the proximal subdifferential of the function $f(x) = |x|$ can be performed using Proposition 9 by observing that f is convex. By Proposition 9(i), for $x = 0$, $\zeta \in \partial_P f(0)$ if and only if, for all $y \in \mathbb{R}$,

$$|y| \geq |0| + \zeta(y - 0) = \zeta y. \quad (61)$$

Hence, for $y \geq 0$, (61) implies $\zeta \in (-\infty, 1]$, while, for $y \leq 0$, (61) implies that $\zeta \in [-1, +\infty)$. Therefore, $\zeta \in (-\infty, 1] \cap [-1, +\infty)$, and $\partial_P f(0) = [-1, 1]$. By Proposition 9(iii), for $x > 0$, $\partial_P f(x) = \{1\}$, and, for $x < 0$, $\partial_P f(x) = \{-1\}$. ■

Regarding critical points, if x is a local minimizer of the lower semicontinuous function $f : \mathbb{R}^d \rightarrow \mathbb{R}$, then $0 \in \partial_P f(x)$. Conversely, if f is convex, and $0 \in \partial_P f(x)$, then x is a global minimizer of f . For the study of maximizers, instead of lower semicontinuous function, convex function, and proximal subdifferential, the relevant notions are upper semicontinuous function, concave function, and proximal superdifferential, respectively [24].

Gradient differential inclusion of a convex function

It is not always possible to associate a nonsmooth gradient flow with a lower semicontinuous function because the proximal subdifferential might be empty almost everywhere. However, following Proposition 9(ii), we can associate a nonsmooth gradient flow with each convex function, as we briefly discuss next [49].

Let $f : \mathbb{R}^d \rightarrow \mathbb{R}$ be convex, and consider the gradient differential inclusion

$$\dot{x}(t) \in -\partial_P f(x(t)). \quad (62)$$

Using the properties of the proximal subdifferential given by Proposition 9(ii), the existence of a Caratheodory solution of (62) starting from every initial condition is guaranteed by Proposition S1. Moreover, the uniqueness of Caratheodory solutions can be established as follows. Let $x, y \in \mathbb{R}^d$, and take $\zeta_1 \in -\partial_P f(x)$ and $\zeta_2 \in -\partial_P f(y)$. Using Proposition 9(i), we have

$$f(y) \geq f(x) - \zeta_1(y - x), \quad f(x) \geq f(y) - \zeta_2(x - y).$$

From here, we deduce $-\zeta_1(y - x) \leq f(y) - f(x) \leq -\zeta_2(y - x)$, and therefore $(\zeta_2 - \zeta_1)(y - x) \leq 0$, which, in particular, implies that the set-valued map $x \mapsto -\partial_P f(x)$ satisfies the one-sided Lipschitz condition (S2). Proposition S2 then guarantees that there exists a unique Caratheodory solution of (62) starting from every initial condition.

Nonsmooth Stability Analysis

In this section, we study the stability of discontinuous dynamical systems. Unless explicitly mentioned otherwise, the stability notions employed here correspond to the usual ones for differential equations, see, for instance [50]. The presentation focuses on the time-invariant differential inclusion

$$\dot{x}(t) \in \mathcal{F}(x(t)), \quad (63)$$

where $\mathcal{F} : \mathbb{R}^d \rightarrow \mathfrak{B}(\mathbb{R}^d)$. Throughout the section, we assume that the set-valued map \mathcal{F} satisfies the hypotheses of Proposition S1, so that the existence of solutions of (63) is guaranteed. The scenario (63) has a direct application to discontinuous differential equations and control systems. For instance, the results presented here apply to Caratheodory solutions by taking a singleton-valued map, to Filippov solutions by taking $\mathcal{F} = F[X]$, and to control systems by taking $\mathcal{F} = G[X]$.

Before proceeding with our exposition, we recall that solutions of a discontinuous system are not necessarily unique. Therefore, when considering a property such as Lyapunov stability, we must

specify whether attention is being paid to a particular solution starting from an initial condition (“weak”) or to all the solutions starting from an initial condition (“strong”). As an example, the set $M \subseteq \mathbb{R}^d$ is *weakly invariant* for (63) if, for each $x_0 \in M$, M contains at least one maximal solution of (63) with initial condition x_0 . Similarly, $M \subseteq \mathbb{R}^d$ is *strongly invariant* for (63) if, for each $x_0 \in M$, M contains every maximal solution of (63) with initial condition x_0 . Rather than reintroducing weak and strong versions of standard stability notions, we rely on the guidance provided above and the context for the specific meaning in each case. Detailed definitions are given in [14, 18].

The following discussion requires the notion of a limit point of a solution of a differential inclusion. The point $x_* \in \mathbb{R}^d$ is a *limit point* of a solution $t \mapsto x(t)$ of (63) if there exists a sequence $\{t_n\}_{n \in \mathbb{N}}$ such that $x(t_n) \rightarrow x_*$ as $n \rightarrow \infty$. We denote by $\Omega(x)$ the set of limit points of $t \mapsto x(t)$. Under the hypotheses of Proposition S1, $\Omega(x)$ is a weakly invariant set. Moreover, if the solution $t \mapsto x(t)$ lies in a bounded, open, and connected set, then $\Omega(x)$ is nonempty, bounded, connected, and $x(t) \rightarrow \Omega(x)$ as $t \rightarrow \infty$, see [18].

Stability analysis by means of the generalized gradient of a nonsmooth Lyapunov function

In this section, we discuss nonsmooth stability analysis results that use locally Lipschitz functions and generalized gradients. We present results taken from various sources in the literature. This discussion is not intended to be a comprehensive account of such a vast topic, but rather serves as a motivation for further exploration. The books [14, 18] and journal articles [51, 52, 53, 54] provide additional information.

Lie derivative and monotonicity

A common theme in stability analysis is establishing the monotonic evolution of a candidate Lyapunov function along the trajectories of the system. Mathematically, the evolution of a function along trajectories is captured by the notion of Lie derivative. Our first task is to generalize this notion to the setting of differential inclusions following [53], see also [51, 52].

Given a locally Lipschitz function $f : \mathbb{R}^d \rightarrow \mathbb{R}$ and a set-valued map $\mathcal{F} : \mathbb{R}^d \rightarrow \mathfrak{B}(\mathbb{R}^d)$, the *set-valued Lie derivative* $\tilde{\mathcal{L}}_{\mathcal{F}}f : \mathbb{R}^d \rightarrow \mathfrak{B}(\mathbb{R})$ of f with respect to \mathcal{F} at x is defined as

$$\tilde{\mathcal{L}}_{\mathcal{F}}f(x) = \{a \in \mathbb{R} : \text{there exists } v \in \mathcal{F}(x) \text{ such that } \zeta^T v = a \text{ for all } \zeta \in \partial f(x)\}. \quad (64)$$

If \mathcal{F} takes convex and compact values, then, for each $x \in \mathbb{R}^d$, $\tilde{\mathcal{L}}_{\mathcal{F}}f(x)$ is a closed and bounded interval in \mathbb{R} , possibly empty. If f is continuously differentiable at x , then

$$\tilde{\mathcal{L}}_{\mathcal{F}}f(x) = \{(\nabla f(x))^T v : v \in \mathcal{F}(x)\}.$$

The usefulness of the set-valued Lie derivative stems from the fact that it allows us to study how the function f evolves along the solutions of a differential inclusion without having to explicitly obtain the solutions. Specifically, we have the following result, see [53].

Proposition 10. *Let $x : [0, t_1] \rightarrow \mathbb{R}^d$ be a solution of the differential inclusion (63), and let $f : \mathbb{R}^d \rightarrow \mathbb{R}$ be locally Lipschitz and regular. Then, the following statements hold:*

(i) *The composition $t \mapsto f(x(t))$ is differentiable at almost all $t \in [0, t_1]$.*

(ii) *The derivative of $t \mapsto f(x(t))$ satisfies*

$$\frac{d}{dt}(f(x(t))) \in \tilde{\mathcal{L}}_{\mathcal{F}}f(x(t)) \quad \text{for almost every } t \in [0, t_1]. \quad (65)$$

A similar result can be established for a larger class of functions when the set-valued map \mathcal{F} is singleton-valued [54, 55].

Given the discontinuous vector field $X : \mathbb{R}^d \rightarrow \mathbb{R}^d$, consider the Filippov solutions of (10). In this case, with a slight abuse of notation, we denote $\tilde{\mathcal{L}}_X f = \tilde{\mathcal{L}}_{F[X]}f$. Note that if X is continuous at x , then $F[X](x) = \{X(x)\}$, and therefore, $\tilde{\mathcal{L}}_X f(x)$ corresponds to the singleton $\{\mathcal{L}_X f(x)\}$, whose sole element is the usual Lie derivative of f in the direction of X at x .

Example 3 revisited: Monotonicity in the nonsmooth harmonic oscillator

For the nonsmooth harmonic oscillator in Example 3, consider the locally Lipschitz and regular map $f : \mathbb{R}^2 \rightarrow \mathbb{R}$, $f(x_1, x_2) = |x_1| + \frac{x_2^2}{2}$. Recall that Figure 3(b) shows the contour plot of f . Let us determine how f evolves along the Filippov solutions of the dynamical system by looking at the set-valued Lie derivative. First, we compute the generalized gradient of f . To do so, we rewrite f as $f(x_1, x_2) = \max\{x_1, -x_1\} + \frac{x_2^2}{2}$, and apply Proposition 7(ii) and the sum rule to find

$$\partial f(x_1, x_2) = \begin{cases} \{(\text{sign}(x_1), x_2)\}, & x_1 \neq 0, \\ [-1, 1] \times \{x_2\}, & x_1 = 0. \end{cases}$$

With this information, we can compute the set-valued Lie derivative $\tilde{\mathcal{L}}_X f : \mathbb{R}^2 \rightarrow \mathfrak{B}(\mathbb{R})$ as

$$\tilde{\mathcal{L}}_X f(x_1, x_2) = \begin{cases} \{0\}, & x_1 \neq 0, \\ \emptyset, & x_1 = 0 \text{ and } x_2 \neq 0, \\ \{0\}, & x_1 = 0 \text{ and } x_2 = 0. \end{cases} \quad (66)$$

From (65) and (66) we conclude that f is constant along the Filippov solutions of the discontinuous dynamical system. Indeed, the level sets of f are exactly the curves described by the solutions of the system in Figure 3(b). ■

Stability results

The above discussion on monotonicity is the stepping stone to stability results using locally Lipschitz functions and generalized gradient information. Proposition 10 provides a criterion for

determining the monotonic behavior of a locally Lipschitz function along the solutions of discontinuous dynamics. This result, together with the appropriate positive definite assumptions on the candidate Lyapunov function, allows us to synthesize checkable stability tests. We start by formulating [53] the natural extension of Lyapunov's stability theorem for ordinary differential equations. Recall that, at each $x \in \mathbb{R}^d$, the Lie derivative $\tilde{\mathcal{L}}_{\mathcal{F}}f(x)$ is a set contained in \mathbb{R} . For the empty set, we adopt the convention $\max \emptyset = -\infty$.

Theorem 1. *Let $\mathcal{F} : \mathbb{R}^d \rightarrow \mathfrak{B}(\mathbb{R}^d)$ be a set-valued map satisfying the hypotheses of Proposition S1, let x_e be an equilibrium of the differential inclusion (63), and let $\mathcal{D} \subseteq \mathbb{R}^d$ be an open and connected set with $x_e \in \mathcal{D}$. Furthermore, let $f : \mathbb{R}^d \rightarrow \mathbb{R}$ be such that the following conditions hold:*

- (i) f is locally Lipschitz and regular on \mathcal{D} .
- (ii) $f(x_e) = 0$, and $f(x) > 0$ for $x \in \mathcal{D} \setminus \{x_e\}$.
- (iii) $\max \tilde{\mathcal{L}}_{\mathcal{F}}f(x) \leq 0$ for each $x \in \mathcal{D}$.

Then, x_e is a strongly stable equilibrium of (63). In addition, if (iii) above is replaced by

(iii)', $\max \tilde{\mathcal{L}}_{\mathcal{F}}f(x) < 0$ for each $x \in \mathcal{D} \setminus \{x_e\}$,

then x_e is a strongly asymptotically stable equilibrium of (63).

Let us apply this result to the nonsmooth harmonic oscillator.

Example 3 revisited: Stability analysis of the nonsmooth harmonic oscillator

The function $(x_1, x_2) \rightarrow |x_1| + \frac{x_2^2}{2}$ satisfies hypotheses (i)-(iii) of Theorem 1 on $\mathcal{D} = \mathbb{R}^d$. Therefore, we conclude that 0 is a strongly stable equilibrium. The phase portrait in Figure 3(a) indicates that 0 is not strongly asymptotically stable. Using Theorem 1, it can be shown that the nonsmooth harmonic oscillator under dissipation, with vector field $(x_1, x_2) \mapsto (x_2, -\text{sign}(x_1) - k \text{sign}(x_2))$, where $k > 0$, has 0 as a strongly asymptotically stable equilibrium. The phase portrait of this system is plotted in Figure 11(a), while several Filippov solutions are plotted in Figure 11(b). ■

Another useful result in the theory of differential equations is the invariance principle [50]. In many situations, this principle allows us to determine the asymptotic convergence properties of the solutions of a differential equation. Here, we build on the above discussion to present a generalization to differential inclusions (63) and nonsmooth Lyapunov functions. This principle is thus applicable to discontinuous differential equations. The formulation is taken from [53], which slightly generalizes the presentation in [51].

Theorem 2. *Let $\mathcal{F} : \mathbb{R}^d \rightarrow \mathfrak{B}(\mathbb{R}^d)$ be a set-valued map satisfying the hypotheses of Proposition S1, and let $f : \mathbb{R}^d \rightarrow \mathbb{R}$ be a locally Lipschitz and regular function. Let $S \subset \mathbb{R}^d$ be*

compact and strongly invariant for (63), and assume that $\max \tilde{\mathcal{L}}_{\mathcal{F}} f(y) \leq 0$ for each $y \in S$. Then, all solutions $x : [0, \infty) \rightarrow \mathbb{R}^d$ of (63) starting at S converge to the largest weakly invariant set M contained in

$$S \cap \overline{\{y \in \mathbb{R}^d : 0 \in \tilde{\mathcal{L}}_{\mathcal{F}} f(y)\}}.$$

Moreover, if the set M consists of a finite number of points, then the limit of each solution starting in S exists and is an element of M .

We now apply Theorem 2 to nonsmooth gradient flows.

Stability of nonsmooth gradient flows

Consider the nonsmooth gradient flow (48) of a locally Lipschitz function $f : \mathbb{R}^d \rightarrow \mathbb{R}$. Assume further that f is regular. Let us examine how f evolves along the solutions of the flow using the set-valued Lie derivative. Given $x \in \mathbb{R}^d$, let $a \in \tilde{\mathcal{L}}_{-\text{Ln}(\partial f)} f(x)$. By definition, there exists $v \in F[-\text{Ln}(\partial f)](x)$ such that

$$a = \zeta^T v \quad \text{for all } \zeta \in \partial f(x). \quad (67)$$

Recall from (49) that $F[-\text{Ln}(\partial f)](x) = -\partial f(x)$. Since (67) holds for all elements in the generalized gradient of f at x , we can choose in particular $\zeta = -v \in \partial f(x)$. Therefore,

$$a = (-v)^T v = -\|v\|_2^2 \leq 0. \quad (68)$$

From (68), we conclude that all of the elements of $\tilde{\mathcal{L}}_{-\text{Ln}(\partial f)} f$ belong to $(-\infty, 0]$, and therefore, from (65), f monotonically decreases along the solutions of its nonsmooth gradient flow (48). Moreover, we deduce that $0 \in \tilde{\mathcal{L}}_{-\text{Ln}(\partial f)} f(x)$ if and only if $0 \in \partial f(x)$, that is, if x is a critical point of f . The application of the Lyapunov stability theorem and the invariance principle in theorems 1 and 2, respectively, gives rise to the following nonsmooth counterpart of the classical smooth result for a gradient flow [56].

Proposition 11. *Let $f : \mathbb{R}^d \rightarrow \mathbb{R}$ be locally Lipschitz and regular. Then, the strict minimizers of f are strongly stable equilibria of the nonsmooth gradient flow (48) of f . Furthermore, if the level sets of f are bounded, then the solutions of the nonsmooth gradient flow asymptotically converge to the set of critical points of f .*

The following example illustrates the above discussion.

Example 16 revisited: Stability analysis of the nonsmooth gradient flow of $-\text{sm}_Q$

Consider the nonsmooth gradient flow of $-\text{sm}_Q$, which is the minimum-distance-to-polygonal-boundary function introduced in Example 16. Proposition 5 guarantees Uniqueness of solutions for this flow. Regarding convergence, Proposition 11 guarantees that solutions converge asymptotically

to the incenter set. Indeed, the incenter set is attained in finite time, and hence each solution converges to a point of the incenter set [44]. The nonsmooth gradient flow can be interpreted as a sphere-packing algorithm in the sense that, starting from an arbitrary initial point, the flow monotonically maximizes the radius of the largest disk contained in the polygon (that is, sm_Q !) until it reaches an incenter point. This fact is illustrated in Figure 12.

What if, instead, we want to pack an arbitrary number n of spheres within the polygon? It turns out that the move-away-from-nearest-neighbor interaction law is a discontinuous dynamical system that solves this problem, where the solutions are understood in the Filippov sense. Figure 13 illustrates the evolution of this dynamical system. The stability properties of this law can be determined using the Lyapunov function $\mathcal{H}_{\text{SP}} : Q^n \rightarrow \mathbb{R}$ defined by

$$\mathcal{H}_{\text{SP}}(p_1, \dots, p_n) = \min\{\frac{1}{2}\|p_i - p_j\|_2, \text{dist}(p_i, e) : i \neq j \in \{1, \dots, n\}, e \text{ edge of } Q\}. \quad (69)$$

The value of \mathcal{H}_{SP} corresponds to the largest radius such that spheres with centers p_1, \dots, p_n and radius $\mathcal{H}_{\text{SP}}(p_1, \dots, p_n)$ fit within the environment and do not intersect each other (except at most at the boundary). The function \mathcal{H}_{SP} is locally Lipschitz, but not concave, on Q , and its evolution is monotonically nondecreasing along the move-away-from-nearest-neighbor dynamical system. The reader is referred to [44] for details on the relationship between \mathcal{H}_{SP} and the minimum distance function sm_Q , as well as additional discontinuous dynamical systems that solve this sphere-packing problem and other exciting geometric optimization problems. ■

Finite-time-convergent nonsmooth gradient flows

Convergence of the solutions of a dynamical system in finite time is a desirable property in various settings. For instance, a motion planning algorithm is effective if it can steer a robot from the initial to the final configuration in finite time rather than asymptotically. Another example is given by a robotic network trying to agree on the exact value of a quantity sensed by each agent. Reaching agreement in finite time allows the network to use precise information in the completion of other tasks.

Broadly applicable results on finite-time convergence for discontinuous dynamical systems can be found in [36, 57, 58, 59]. Here, we briefly discuss the finite-convergence properties of a class of nonsmooth gradient flows. Let $f : \mathbb{R}^d \rightarrow \mathbb{R}$ be a continuously differentiable function and assume that all of the level sets of f are bounded. It is well known [56] that all solutions of the gradient flow $\dot{x}(t) = -\nabla f(x(t))$ converge asymptotically toward the set of critical points of f , although the convergence does not occur in finite time. Here, we slightly modify the gradient flow into two different nonsmooth flows that achieve finite-time convergence. Consider the discontinuous differential equations

$$\dot{x}(t) = -\frac{\nabla f(x(t))}{\|\nabla f(x(t))\|_2}, \quad (70)$$

$$\dot{x}(t) = -\text{sign}(\nabla f(x(t))), \quad (71)$$

where $\|\cdot\|_2$ denotes the Euclidean distance, and $\text{sign}(x) = (\text{sign}(x_1), \dots, \text{sign}(x_d)) \in \mathbb{R}^d$. The nonsmooth vector field (70) always points in the direction of the gradient with unit speed. Alternatively, the nonsmooth vector field (71) specifies the direction of motion by means of a binary

quantization of the direction of the gradient. The following result [57] characterizes the properties of the Filippov solutions of (70) and (71).

Proposition 12. *Let $f : \mathbb{R}^d \rightarrow \mathbb{R}$ be a twice continuously differentiable function. Let $S \subset \mathbb{R}^d$ be compact and strongly invariant for (70) (resp., for (71)). If the Hessian of f is positive definite at every critical point of f in S , then every Filippov solution of (70) (resp. (71)) starting from S converges in finite time to a minimizer of f .*

The proof of Proposition 12 builds on the stability tools presented in this section. Specifically, the invariance principle can be used to establish convergence toward the set of critical points of f . Finite-time convergence can be established by deriving bounds on the evolution of f along the solutions of the discontinuous dynamics using the set-valued Lie derivative. This analysis also allows us to provide upper bounds on the convergence time. A more comprehensive exposition of results that guarantee finite-time convergence of general discontinuous dynamics is given in [57].

Example 19: Finite-time consensus

The ability to reach consensus, or agreement, upon some (a priori unknown) quantity is critical for multi-agent systems. Network coordination problems require that individual agents agree on the identity of a leader, jointly synchronize their operation, decide which specific pattern to form, balance the computational load, or fuse consistently the information gathered on some spatial process. Here, we briefly comment on two discontinuous algorithms that achieve consensus in finite time, following [57].

Consider a network of n agents with states $p_1, \dots, p_n \in \mathbb{R}$. Let $G = (\{1, \dots, n\}, E)$ be an undirected graph with n vertices, describing the topology of the network. Two agents i and j agree if and only if $p_i = p_j$. The *disagreement function* $\Phi_G : \mathbb{R}^n \rightarrow [0, \infty)$ quantifies the group disagreement

$$\Phi_G(p_1, \dots, p_n) = \frac{1}{2} \sum_{(i,j) \in E} (p_j - p_i)^2.$$

It is known [60] that, if the graph is connected, the gradient flow of Φ_G achieves consensus with an exponential rate of convergence. Actually, agents agree on the average value of their initial states (this consensus is called *average consensus*). If G is connected, the nonsmooth gradient flow (70) of Φ_G achieves average consensus in finite time, and the nonsmooth gradient flow (71) of Φ_G achieves consensus on the average of the maximum and the minimum of the initial states in finite time, see [57]. ■

Stability analysis by means of the proximal subdifferential of a nonsmooth Lyapunov function

This section presents stability tools for differential inclusions using a lower semicontinuous function as a candidate Lyapunov function. We use the proximal subdifferential to study the monotonic

evolution of the candidate Lyapunov function along the solutions of the differential inclusion. As in the previous section, we present a few representative and useful results. We refer the interested reader to [24, 25] for a more detailed exposition.

Lie derivative and monotonicity

Let $\mathcal{D} \subseteq \mathbb{R}^d$ be an open and connected set. A lower semicontinuous function $f : \mathbb{R}^d \rightarrow \mathbb{R}$ is *weakly nonincreasing on \mathcal{D}* for a set-valued map $\mathcal{F} : \mathbb{R}^d \rightarrow \mathfrak{B}(\mathbb{R}^d)$ if, for all $y \in \mathcal{D}$, there exists a solution $x : [0, t_1] \rightarrow \mathbb{R}^d$ of the differential inclusion (63) starting at y and contained in \mathcal{D} that satisfies

$$f(x(t)) \leq f(x(0)) = f(y) \quad \text{for all } t \in [0, t_1].$$

If, in addition, f is continuous, then being weakly nonincreasing is equivalent to the property of having a solution starting at y such that $t \mapsto f(x(t))$ is monotonically nonincreasing on $[0, t_1]$.

Similarly, a lower semicontinuous function $f : \mathbb{R}^d \rightarrow \mathbb{R}$ is *strongly nonincreasing on \mathcal{D}* for a set-valued map $\mathcal{F} : \mathbb{R}^d \rightarrow \mathfrak{B}(\mathbb{R}^d)$ if, for all $y \in \mathcal{D}$, all solutions $x : [0, t_1] \rightarrow \mathbb{R}^d$ of the differential inclusion (63) starting at y and contained in \mathcal{D} satisfy

$$f(x(t)) \leq f(x(0)) = f(y) \quad \text{for all } t \in [0, t_1].$$

Note that f is strongly nonincreasing if and only if $t \mapsto f(x(t))$ is monotonically nonincreasing on $[0, t_1]$ for all solutions $t \mapsto x(t)$ of the differential inclusion.

Given the set-valued map $\mathcal{F} : \mathbb{R}^d \rightarrow \mathfrak{B}(\mathbb{R}^d)$, which takes nonempty, compact values, and the lower semicontinuous function $f : \mathbb{R}^d \rightarrow \mathbb{R}$, the *lower and upper set-valued Lie derivatives* $\underline{\mathcal{L}}_{\mathcal{F}}f, \overline{\mathcal{L}}_{\mathcal{F}}f : \mathbb{R}^d \rightarrow \mathfrak{B}(\mathbb{R})$ of f with respect to \mathcal{F} at y are defined by, respectively,

$$\begin{aligned} \underline{\mathcal{L}}_{\mathcal{F}}f(y) &\triangleq \{a \in \mathbb{R} : \text{there exists } \zeta \in \partial_P f(y) \text{ such that } a = \min\{\zeta^T v : v \in \mathcal{F}(y)\}\}, \\ \overline{\mathcal{L}}_{\mathcal{F}}f(y) &\triangleq \{a \in \mathbb{R} : \text{there exists } \zeta \in \partial_P f(y) \text{ such that } a = \max\{\zeta^T v : v \in \mathcal{F}(y)\}\}. \end{aligned}$$

If, in addition, \mathcal{F} takes convex values, then for each $\zeta \in \partial_P f(y)$, the set $\{\zeta^T v : v \in \mathcal{F}(y)\}$ is a closed interval of the form $[\min\{\zeta^T v : v \in \mathcal{F}(y)\}, \max\{\zeta^T v : v \in \mathcal{F}(y)\}]$. Note that the lower and upper set-valued Lie derivatives at a point y might be empty.

The lower and upper set-valued Lie derivatives play a role for a lower semicontinuous function that is similar to the role played by the set-valued Lie derivative $\tilde{\mathcal{L}}_{\mathcal{F}}f$ for a locally Lipschitz function. These objects allow us to study how f evolves along the solutions of a differential inclusion without having to obtain the solutions in closed form. Specifically, we have the following result [24]. In this and in forthcoming statements, it is convenient to adopt the convention $\sup \emptyset = -\infty$.

Proposition 13. *Let $\mathcal{F} : \mathbb{R}^d \rightarrow \mathfrak{B}(\mathbb{R}^d)$ be a set-valued map satisfying the hypotheses of Proposition S1, and consider the associated differential inclusion (63). Let $f : \mathbb{R}^d \rightarrow \mathbb{R}$ be a lower semicontinuous function, and let $\mathcal{D} \subseteq \mathbb{R}^d$ be open. Then, the following statements hold:*

(i) *The function f is weakly nonincreasing on \mathcal{D} if and only if*

$$\sup \underline{\mathcal{L}}_{\mathcal{F}}f(y) \leq 0, \quad \text{for all } y \in \mathcal{D}.$$

(ii) If, in addition, either \mathcal{F} is locally Lipschitz on \mathcal{D} , or \mathcal{F} is continuous on \mathcal{D} and f is locally Lipschitz on \mathcal{D} , then f is strongly nonincreasing on \mathcal{D} if and only if

$$\sup \bar{\mathcal{L}}_{\mathcal{F}} f(y) \leq 0, \quad \text{for all } y \in \mathcal{D}.$$

Let us illustrate this result in a particular example.

Example 20: Cart on a circle

Consider, following [25, 61], the control system on \mathbb{R}^2

$$\dot{x}_1 = (x_1^2 - x_2^2)u, \tag{72}$$

$$\dot{x}_2 = 2x_1x_2u, \tag{73}$$

with $u \in \mathbb{R}$. Equations (72)-(73) are named after the fact that the integral curves of the vector field $(x_1, x_2) \mapsto (x_1^2 - x_2^2, 2x_1x_2)$ are circles with center on the x_2 -axis and tangent to the x_1 -axis, see the phase portrait in Figure 14(a).

Let $X : \mathbb{R}^2 \times \mathbb{R} \rightarrow \mathbb{R}^2$ be defined by $X((x_1, x_2), u) = (x_1^2 - x_2^2, 2x_1x_2)u$. Following (34), consider the associated set-valued map $G[X] : \mathbb{R}^2 \rightarrow \mathfrak{B}(\mathbb{R}^2)$ defined by $G[X](x_1, x_2) = \{X((x_1, x_2), u) : u \in \mathbb{R}\}$. Since $G[X]$ does not take compact values, we instead take a nondecreasing map $\sigma : [0, \infty) \rightarrow [0, \infty)$, and consider the set-valued map $\mathcal{F}_\sigma : \mathbb{R}^2 \rightarrow \mathfrak{B}(\mathbb{R}^2)$ given by

$$\mathcal{F}_\sigma(x_1, x_2) = \{X((x_1, x_2), u) \in \mathbb{R}^2 : |u| \leq \sigma(\|(x_1, x_2)\|_2)\}. \tag{74}$$

Consider the locally Lipschitz function $f : \mathbb{R}^2 \rightarrow \mathbb{R}$ defined by

$$f(x_1, x_2) = \begin{cases} \frac{x_1^2 + x_2^2}{\sqrt{x_1^2 + x_2^2} + |x_1|}, & x \neq 0, \\ 0, & x = 0. \end{cases}$$

The level set curves of f are depicted in Figure 14(c). Let us determine how f evolves along the solutions of the control system by using the lower and upper set-valued Lie derivatives. First, we compute the proximal subdifferential of f . Using the fact that f is twice continuously differentiable on the open right and left half-planes, together with the geometric interpretation of proximal subgradients, we obtain

$$\partial_P f(x_1, x_2) = \begin{cases} \left\{ \left(-\frac{x_1^2 + x_2^2 - 2x_1\sqrt{x_1^2 + x_2^2}}{x_1^2 + x_2^2 + x_1\sqrt{x_1^2 + x_2^2}}, \frac{x_2(2x_1 + \sqrt{x_1^2 + x_2^2})}{(x_1 + \sqrt{x_1^2 + x_2^2})^2} \right) \right\}, & x_1 > 0, \\ \emptyset, & x_1 = 0, \\ \left\{ \left(\frac{x_1^2 + x_2^2 + 2x_1\sqrt{x_1^2 + x_2^2}}{x_1^2 + x_2^2 - x_1\sqrt{x_1^2 + x_2^2}}, \frac{x_2(-2x_1 + \sqrt{x_1^2 + x_2^2})}{(x_1 - \sqrt{x_1^2 + x_2^2})^2} \right) \right\}, & x_1 < 0. \end{cases}$$

With this information, we compute the set

$$\begin{aligned} & \{\zeta^T v : \zeta \in \partial_P f(x_1, x_2), v \in \mathcal{F}_\sigma(x_1, x_2)\} \\ &= \begin{cases} \left\{ u \frac{(x_1^2 + x_2^2)^2}{x_1^2 + x_2^2 + x_1 \sqrt{x_1^2 + x_2^2}} : |u| \leq \sigma(\|(x_1, x_2)\|_2) \right\}, & x_1 > 0, \\ \emptyset, & x_1 = 0, \\ \left\{ -u \frac{(x_1^2 + x_2^2)^2}{x_1^2 + x_2^2 - x_1 \sqrt{x_1^2 + x_2^2}} : |u| \leq \sigma(\|(x_1, x_2)\|_2) \right\}, & x_1 < 0. \end{cases} \end{aligned}$$

We are now ready to compute the lower and upper set-valued Lie derivatives as

$$\underline{\mathcal{L}}_{\mathcal{F}_\sigma} f(x_1, x_2) = \begin{cases} -\sigma(\|(x_1, x_2)\|_2) \frac{(x_1^2 + x_2^2)^{3/2}}{\sqrt{x_1^2 + x_2^2 + |x_1|}}, & x_1 \neq 0, \\ -\infty, & x_1 = 0, \end{cases} \quad (75)$$

$$\overline{\mathcal{L}}_{\mathcal{F}_\sigma} f(x_1, x_2) = \begin{cases} \sigma(\|(x_1, x_2)\|_2) \frac{(x_1^2 + x_2^2)^{3/2}}{\sqrt{x_1^2 + x_2^2 + |x_1|}}, & x_1 \neq 0, \\ -\infty, & x_1 = 0. \end{cases} \quad (76)$$

Therefore, $\sup \underline{\mathcal{L}}_{\mathcal{F}_\sigma} f(x_1, x_2) \leq 0$ for all $(x_1, x_2) \in \mathbb{R}^2$. Now using Proposition 13(i), we deduce that f is weakly nonincreasing on \mathbb{R}^2 . Since f is continuous, this fact is equivalent to saying that there exists a control input u such that the solution $t \mapsto x(t)$ of the dynamical system resulting from substituting u in (72)-(73) has the property that $t \mapsto f(x(t))$ is monotonically nonincreasing. ■

Stability results

The results presented in the previous section establishing the monotonic behavior of a lower semi-continuous function allow us to provide tools for stability analysis. We present here an exposition parallel to the discussion for the locally Lipschitz function and generalized gradient case. We start by presenting a result on Lyapunov stability that follows from the exposition in [24].

Theorem 3. *Let $\mathcal{F} : \mathbb{R}^d \rightarrow \mathfrak{B}(\mathbb{R}^d)$ be a set-valued map satisfying the hypotheses of Proposition S1. Let x_e be an equilibrium of the differential inclusion (63), and let $\mathcal{D} \subseteq \mathbb{R}^d$ be a domain with $x_e \in \mathcal{D}$. Let $f : \mathbb{R}^d \rightarrow \mathbb{R}$ and assume that the following conditions hold:*

- (i) \mathcal{F} is continuous on \mathcal{D} and f is locally Lipschitz on \mathcal{D} , or \mathcal{F} is locally Lipschitz on \mathcal{D} and f is lower semicontinuous on \mathcal{D} , and f is continuous at x_e .
- (ii) $f(x_e) = 0$, and $f(x) > 0$ for $x \in \mathcal{D} \setminus \{x_e\}$.
- (iii) $\sup \overline{\mathcal{L}}_{\mathcal{F}} f(x) \leq 0$ for all $x \in \mathcal{D}$.

Then, x_e is a strongly stable equilibrium of (63). In addition, if (iii) above is replaced by

$$(iii)' \sup \overline{\mathcal{L}}_{\mathcal{F}} f(x) < 0 \text{ for all } x \in \mathcal{D} \setminus \{x_e\},$$

then x_e is a strongly asymptotically stable equilibrium of (63).

A similar result can be stated for weakly stable equilibria substituting (i) by “(i)’ f is continuous on \mathcal{D} ,” and the upper set-valued Lie derivative by the lower set-valued Lie derivative in (iii) and (iii)’. Note that, if the differential inclusion (63) has a unique solution starting from every initial conditions, then the notions of strong and weak stability coincide, and it is sufficient to satisfy the simpler requirements (i)’ and (iii)’ for weak stability.

Similarly to the case of a continuous differential equation, global asymptotic stability can be established by requiring the Lyapunov function f to be continuous and radially unbounded. The equivalence between global strong asymptotic stability and the existence of infinitely differentiable Lyapunov functions is discussed in [62]. This type of global result is commonly invoked when dealing with the stabilization of control systems by referring to control Lyapunov functions [25] or Lyapunov pairs [24]. Two lower semicontinuous functions $f, g : \mathbb{R}^d \rightarrow \mathbb{R}$ are a *Lyapunov pair* for an equilibrium $x_e \in \mathbb{R}^d$ if they satisfy $f(x), g(x) \geq 0$ for all $x \in \mathbb{R}^d$, and $g(x) = 0$ if and only if $x = x_e$; f is radially unbounded, and, moreover,

$$\sup \underline{\mathcal{L}}_{\mathcal{F}} f(x) \leq -g(x) \quad \text{for all } x \in \mathbb{R}^d.$$

If an equilibrium x_e of (63) admits a Lyapunov pair, then there exists at least one solution starting from every initial condition that asymptotically converges to the equilibrium, see [24].

Example 20 revisited: Asymptotic stability of the origin in the cart example

As an application of the above discussion and the version of Theorem 3 for weak stability, consider the cart on a circle introduced in Example 20. Setting $x_e = (0, 0)$ and $\mathcal{D} = \mathbb{R}^2$, and taking into account the computation (75) of the lower set-valued Lie derivative, we conclude that $(0, 0)$ is a globally weakly asymptotically stable equilibrium. ■

We now turn our attention to the extension of the invariance principle for differential inclusions using the proximal subdifferential of a lower semicontinuous function. The following result can be derived from the exposition in [24].

Theorem 4. *Let $\mathcal{F} : \mathbb{R}^d \rightarrow \mathfrak{B}(\mathbb{R}^d)$ be a set-valued map satisfying the hypotheses of Proposition S1, and let $f : \mathbb{R}^d \rightarrow \mathbb{R}$. Assume that either \mathcal{F} is continuous and f is locally Lipschitz, or \mathcal{F} is locally Lipschitz and f is continuous. Let $S \subset \mathbb{R}^d$ be compact and strongly invariant for (63), and assume that $\sup \overline{\mathcal{L}}_{\mathcal{F}} f(y) \leq 0$ for all $y \in S$. Then, every solution $x : [0, \infty) \rightarrow \mathbb{R}^d$ of (63) starting at S converges to the largest weakly invariant set M contained in*

$$S \cap \overline{\{y \in \mathbb{R}^d : 0 \in \overline{\mathcal{L}}_{\mathcal{F}} f(y)\}}.$$

Moreover, if the set M consists of a finite number of points, then the limit of each solution starting in S exists and is an element of M .

Next, we apply Theorem 4 to gradient differential inclusions.

Stability of gradient differential inclusions for convex functions

Consider the gradient differential inclusion (62) associated with the convex function $f : \mathbb{R}^d \rightarrow \mathbb{R}$. We study here the asymptotic behavior of the solutions of (62). From the section “Gradient differential inclusion of a convex function,” we know that solutions exist and are unique. Consequently, the notions of weakly nonincreasing and strongly nonincreasing function coincide. Therefore, it suffices to show that f is weakly nonincreasing on \mathbb{R}^d for the gradient differential inclusion (62).

For all $\zeta \in \partial_P f(x)$, there exists $v = -\zeta \in -\partial_P f(x)$ such that $\zeta^T v = -\|\zeta\|_2^2 \leq 0$. Hence,

$$\underline{\mathcal{L}}_{-\partial_P f} f(x) \leq 0 \quad \text{for all } x \in \mathbb{R}^d.$$

Proposition 13(i) now guarantees that f is weakly nonincreasing on \mathbb{R}^d . Since the solutions of the gradient differential inclusion (62) are unique, $t \mapsto f(x(t))$ is monotonically nonincreasing for all solutions $t \mapsto x(t)$.

The application of the Lyapunov stability theorem and the invariance principle in theorems 3 and 4, respectively, gives rise to the following nonsmooth counterpart of the classical smooth result for a gradient flow [56].

Proposition 14. *Let $f : \mathbb{R}^d \rightarrow \mathbb{R}$ be convex. Then, the strict minimizers of f are strongly stable equilibria of the gradient differential inclusion (62) associated with f . Furthermore, if the level sets of f are bounded, then the solutions of the gradient differential inclusion asymptotically converge to the set of minimizers of f .*

Convergence rate estimates of (62) can be found in [63].

Stabilization of control systems

Consider the control system on \mathbb{R}^d given by

$$\dot{x} = X(x, u), \tag{77}$$

where $X : \mathbb{R}^d \times \mathbb{R}^m \rightarrow \mathbb{R}^d$. The system (77) is locally (respectively, globally) *continuously stabilizable* if there exists a continuous map $k : \mathbb{R}^d \rightarrow \mathbb{R}^m$ such that the closed-loop system

$$\dot{x} = X(x, k(x))$$

is locally (respectively globally) asymptotically stable at the origin. The following result by Brockett [13], see also [12, 14], states that a large class of control systems are not stabilizable by a continuous feedback controller.

Theorem 5. *Let $X : \mathbb{R}^d \times \mathbb{R}^m \rightarrow \mathbb{R}^d$ be continuous and $X(0, 0) = 0$. If there exists a continuous stabilizer of the control system (77), then there exists a neighborhood of the origin in $\mathbb{R}^d \times \mathbb{R}^m$ whose image by X is a neighborhood of the origin in \mathbb{R}^d .*

In particular, Theorem 5 implies that control systems of the form

$$\dot{x} = u_1 X_1(x) + \cdots + u_m X_m(x), \tag{78}$$

with $m < n$ and $X_i : \mathbb{R}^d \rightarrow \mathbb{R}^d$, $i \in \{1, \dots, m\}$, continuous with $\text{rank}(X_1(0), \dots, X_m(0)) = m$, cannot be stabilized by a continuous feedback controller.

Example 21: Nonholonomic integrator

Consider the nonholonomic integrator [64]

$$\dot{x}_1 = u_1, \tag{79}$$

$$\dot{x}_2 = u_2, \tag{80}$$

$$\dot{x}_3 = x_1 u_2 - x_2 u_1, \tag{81}$$

where $(u_1, u_2) \in \mathbb{R}^2$. The nonholonomic integrator is a control system of the form (78), with $m = 2$, $X_1(x_1, x_2, x_3) = (1, 0, -x_2)$, and $X_2(x_1, x_2, x_3) = (0, 1, x_1)$. The nonholonomic integrator is controllable, that is, for each pair of states $x, y \in \mathbb{R}^3$, there exists an input $t \mapsto u(t)$ such that the corresponding solution of (79)-(81) starting at x reaches y . However, the nonholonomic integrator does not satisfy the condition in Theorem 5, and thus is not continuously stabilizable. Indeed, no point of the form $(0, 0, \varepsilon)$, where $\varepsilon \neq 0$, belongs to the image of the map $X : \mathbb{R}^3 \times \mathbb{R}^2 \rightarrow \mathbb{R}^3$, $X(x_1, x_2, x_3, u_1, u_2) = (u_1, u_2, x_1 u_2 - x_2 u_1)$. ■

The condition in Theorem 5 is necessary but not sufficient. There exist control systems that satisfy the condition, and still cannot be stabilized by means of a continuous stabilizer. The cart on a circle in Example 20 is one of these systems. The map $((x_1, x_2), u) \rightarrow X(x_1, x_2, u)$ satisfies the necessary condition in Theorem 5 but cannot be stabilized with a continuous $k : \mathbb{R}^2 \rightarrow \mathbb{R}$, see [25].

Another obstruction to the existence of continuous stabilizing controllers is given by Milnor's theorem [12], which states that the domain of attraction of an asymptotically stable equilibrium of a locally Lipschitz vector field must be diffeomorphic to Euclidean space. Since environments with obstacles are not diffeomorphic to Euclidean space, one can use Milnor's theorem to justify [25] the nonexistence of continuous globally stabilizing controllers in environments with obstacles.

The obstruction to the existence of continuous stabilizers has motivated the search for time-varying and discontinuous feedback stabilizers. Regarding the latter, given a discontinuous $k : \mathbb{R}^d \rightarrow \mathbb{R}^m$, the immediate question that arises is how to understand the solutions of the resulting discontinuous dynamical system $\dot{x} = X(x, k(x))$. From the previous discussion, we know that Caratheodory solutions are not a good candidate, since in many situations they fail to exist. The following result [21, 22] shows that Filippov solutions are also not a good candidate.

Theorem 6. *Let $X : \mathbb{R}^d \times \mathbb{R}^m \rightarrow \mathbb{R}^d$ be continuous and $X(0, 0) = 0$. Assume that, for each $U \subseteq \mathbb{R}^m$ and each $x \in \mathbb{R}^d$, $X(x, \text{co } U) = \text{co } X(x, U)$ holds. With solutions understood in the Filippov sense, if there exists a measurable, locally bounded stabilizer of the control system (77), then there exists a neighborhood of the origin in $\mathbb{R}^d \times \mathbb{R}^m$ whose image by X is a neighborhood of the origin in \mathbb{R}^d .*

In particular, control systems of the form (78) cannot be stabilized by means of a discontinuous feedback if solutions are understood in the Filippov sense. This impossibility result, however, can be overcome if solutions are understood in the sample-and-hold sense, as shown in [41]. Let us briefly discuss this result in the light of the above exposition. For more details, see [24, 25, 26]. Consider the differential inclusion (35) associated with the control system (77). The system (77) is (*open loop*) *globally asymptotically controllable* (to the origin) if 0 is a Lyapunov weakly stable

equilibrium of the differential inclusion (35), and every point $y \in \mathbb{R}^d$ has the property that there exists a solution of (35) satisfying $x(0) = y$ and $\lim_{t \rightarrow \infty} x(t) = 0$. On the other hand, a map $k : \mathbb{R}^d \rightarrow \mathbb{R}^m$ stabilizes the system (77) in the sample-and-hold sense if, for all $x_0 \in \mathbb{R}^d$ and all $\varepsilon \in (0, \infty)$, there exist $\delta, T \in (0, \infty)$ such that, for all partitions π of $[0, t_1]$ with $\text{diam}(\pi) < \delta$, the corresponding π -solution $t \mapsto x(t)$ of (77) starting at x_0 satisfies $\|x(t)\|_2 \leq \varepsilon$ for all $t \geq T$.

The following result [41] states that both notions, global asymptotic controllability and the existence of a feedback stabilizer in the sample-and-hold sense, are equivalent.

Theorem 7. *Let $X : \mathbb{R}^d \times \mathbb{R}^m \rightarrow \mathbb{R}^d$ be continuous and $X(0, 0) = 0$. Then, the control system (77) is globally asymptotically controllable if and only if it admits a measurable, locally bounded stabilizer in the sample-and-hold sense.*

The “only if” implication is clear. The converse implication is proved by explicit construction of the stabilizer, and is based on the fact that the control system (77) is globally asymptotically controllable if and only if it admits a continuous Lyapunov pair, see [65]. Using the continuous Lyapunov function provided by this characterization, the discontinuous feedback for the control system (77) can be constructed explicitly [25, 41].

The existence of a Lyapunov pair in the sense of generalized gradients (that is, when the set-valued Lie derivative involving the generalized gradient is used instead of the lower set-valued Lie derivative involving the proximal subdifferential), however, turns out to be equivalent to the existence of a stabilizing feedback in the sense of Filippov, see [66].

Example 20 revisited: Cart stabilization by discontinuous feedback

As an illustration, consider Example 20. We have already shown that $(0, 0)$ is a globally weakly asymptotically stable equilibrium of the differential inclusion (74) associated with the control system. Therefore, the control system is globally asymptotically controllable, and can be stabilized in the sample-and-hold sense by means of a discontinuous feedback. The stabilizing feedback that results from the proof of Theorem 7 can be described as follows, see [25, 67]. If placed to the left of the x_2 axis, move in the direction of the vector field g . If placed to the right of the x_2 axis, move in the opposite direction of the vector field g . Finally, on the x_2 -axis, choose an arbitrary direction. The stabilizing nature of this feedback can be graphically checked in Figure 14(a) and (b). ■

Remarkably, for a system that is affine in the controls, it is possible to show [68] that there exists a stabilizing feedback controller whose discontinuities form a set of measure zero, and, moreover, the discontinuity set is repulsive for the solutions of the closed-loop system. In particular, this fact means that, for the closed-loop system, the solutions can be understood in the Caratheodory sense. This situation exactly corresponds to the situation in Example 20.

Conclusions

This article has presented an introductory tutorial on discontinuous dynamical systems. Various examples illustrate the pertinence of the continuity and Lipschitzness properties that guarantee the existence and uniqueness of classical solutions to ordinary differential equations. The lack of these properties in examples drawn from various disciplines motivates the need for more general notions than the classical one. This observation is the starting point into the three main themes of our discussion. First, we introduced notions of solution for discontinuous systems. Second, we reviewed the available tools from nonsmooth analysis to study the gradient information of candidate Lyapunov functions. And, third, we presented nonsmooth stability tools to characterize the asymptotic behavior of solutions.

The physical significance of the solution notions discussed in this article depend on the specific setting. Caratheodory solutions are employed for time-dependent vector fields that depend discontinuously on time, such as dynamical systems involving impulses as well as control systems with discontinuous open-loop inputs. Filippov solutions are used in problems involving electrical circuits with switches, relay control, friction, and sliding. This observation is also valid for solution notions similar to Filippov's, such as Krasovskii and Sentis solutions, see "Additional Solution Notions for Discontinuous Systems." The notion of a π -solution for control systems has the physical interpretation of iteratively evaluating the input at the current state and holding it steady for some time while the closed-loop dynamical system evolves. As illustrated above, this solution notion plays a pivotal role in the stabilization of asymptotically controllable systems.

There are numerous important issues that are not treated here; "Additional Topics on Discontinuous Systems and Differential Inclusions" lists some of them. The topic of discontinuous dynamical systems is vast, and our focus on the above-mentioned themes is aimed at providing a coherent exposition. We hope that this tutorial serves as a guided motivation for the reader to further explore the exciting topic of discontinuous systems. The list of references of this manuscript provides a good starting point to undertake this endeavor.

Acknowledgments

This research was supported by NSF CAREER Award ECS-0546871. The author wishes to thank Francesco Bullo and Anurag Ganguli for countless hours of fun with Filippov solutions, and Bernard Brogliato, Rafal Goebel, Rishi Graham, and three anonymous reviewers for numerous comments that improved the presentation.

References

- [1] A. A. Agrachev and Y. Sachkov, *Control Theory from the Geometric Viewpoint*. New York: Springer Verlag, 2004.

- [2] S. Bennett, *A History of Control Engineering 1930-1955*. London, UK: Institute of Electrical Engineers, 1993.
- [3] B. Brogliato, *Nonsmooth Impact Mechanics: Models, Dynamics, and Control*. New York: Springer Verlag, 2nd ed., 1999.
- [4] F. Pfeiffer and C. Glocker, *Multibody Dynamics with Unilateral Contacts*. New York: John Wiley, 1996.
- [5] G. A. S. Pereira, M. F. M. Campos, and V. Kumar, “Decentralized algorithms for multi-robot manipulation via caging,” *International Journal of Robotics Research*, vol. 23, no. 7-8, pp. 783–795, 2004.
- [6] V. I. Utkin, *Sliding Modes in Control and Optimization*. New York: Springer Verlag, 1992.
- [7] C. Edwards and S. K. Spurgeon, *Sliding Mode Control: Theory and Applications*. London: Taylor & Francis, 1998.
- [8] R. C. Arkin, *Behavior-Based Robotics*. Cambridge, MA: MIT Press, 1998.
- [9] F. H. Clarke, *Optimization and Nonsmooth Analysis*. Canadian Mathematical Society Series of Monographs and Advanced Texts, John Wiley, 1983.
- [10] A. Bhaya and E. Kaszkurewicz, *Control Perspectives on Numerical Algorithms and Matrix Problems*. Philadelphia, PA: SIAM, 2006.
- [11] M. M. Polycarpou and P. A. Ioannou, “On the existence and uniqueness of solutions in adaptive control systems,” *IEEE Transactions on Automatic Control*, vol. 38, no. 3, pp. 474–479, 1993.
- [12] E. D. Sontag, *Mathematical Control Theory: Deterministic Finite Dimensional Systems*. New York: Springer Verlag, 2 ed., 1998.
- [13] R. W. Brockett, “Asymptotic stability and feedback stabilization,” in *Geometric Control Theory*, R. W. Brockett, R. S. Millman, and H. J. Sussmann, eds. Boston, MA, Birkhäuser Verlag, 1983, pp. 181–191.
- [14] A. Bacciotti and L. Rosier, *Liapunov Functions and Stability in Control Theory*. New York: Springer Verlag, 2nd ed., 2005.
- [15] D. E. Stewart, “Rigid-body dynamics with friction and impact,” *SIAM Review*, vol. 42, no. 1, pp. 3–39, 2000.
- [16] F. Ceragioli, *Discontinuous Ordinary Differential Equations and Stabilization*. PhD thesis, University of Firenze, Italy, 1999. Electronically available at <http://calvino.polito.it/~ceragioli>.
- [17] H. Goldstein, *Classical Mechanics*. Reading, MA: Addison-Wesley, 2 ed., 1980.
- [18] A. F. Filippov, *Differential Equations with Discontinuous Righthand Sides*. Dordrecht, The Netherlands: Kluwer Academic Publishers, 1988.

- [19] J. P. Aubin and A. Cellina, *Differential Inclusions*. New York: Springer Verlag, 1994.
- [20] G. V. Smirnov, *Introduction to the Theory of Differential Inclusions*. Providence, RI: American Mathematical Society, 2001.
- [21] E. P. Ryan, “On Brockett’s condition for smooth stabilizability and its necessity in a context of nonsmooth feedback,” *SIAM Journal on Control and Optimization*, vol. 32, no. 6, pp. 1597–1604, 1994.
- [22] J. M. Coron and L. Rosier, “A relation between continuous time-varying and discontinuous feedback stabilization,” *Journal of Mathematics Systems, Estimation and Control*, vol. 4, no. 1, pp. 67–84, 1994.
- [23] N. N. Krasovskii and A. I. Subbotin, *Game-Theoretical Control Problems*. New York: Springer Verlag, 1988.
- [24] F. H. Clarke, Y. Ledyaev, R. J. Stern, and P. R. Wolenski, *Nonsmooth Analysis and Control Theory*. New York: Springer Verlag, 1998.
- [25] E. D. Sontag, “Stability and stabilization: Discontinuities and the effect of disturbances,” in *Nonlinear Analysis, Differential Equations, and Control*, F. H. Clarke and R. J. Stern, eds. Dordrecht, The Netherlands: Kluwer Academic Publishers, 1999, pp. 551–598.
- [26] F. H. Clarke, “Lyapunov functions and feedback in nonlinear control,” in *Optimal Control, Stabilization and Nonsmooth Analysis*, M. S. de Queiroz, M. Malisoff, and P. Wolenski, eds. New York: Springer Verlag, 2004, pp. 267–282.
- [27] E. A. Coddington and N. Levinson, *Theory of Ordinary Differential Equations*. New York: McGraw-Hill, 1955.
- [28] R. P. Agarwal and V. Lakshmikantham, *Uniqueness and Nonuniqueness Criteria for Ordinary Differential Equations*. Singapore: World Scientific Publishing, 1993.
- [29] A. Pucci, “Traiettorie di campi di vettori discontinui,” *Rend. Ist. Mat. Univ. Trieste*, vol. 8, pp. 84–93, 1976.
- [30] F. Ancona and A. Bressan, “Patchy vector fields and asymptotic stabilization,” *ESAIM. Control, Optimisation & Calculus of Variations*, vol. 4, pp. 419–444, 1999.
- [31] A. Bressan, “Unique solutions for a class of discontinuous differential equations,” *Proceedings of the American Mathematical Society*, vol. 104, no. 3, pp. 772–778, 1988.
- [32] A. Bressan and W. Shen, “Uniqueness for discontinuous o.d.e. and conservation laws,” *Nonlinear Analysis*, vol. 34, pp. 637–652, 1998.
- [33] J.-I. Imura and A. J. van der Schaft, “Characterization of well-posedness of piecewise linear systems,” *IEEE Transactions on Automatic Control*, vol. 45, no. 9, pp. 1600–1619, 2000.
- [34] N. N. Krasovskii, *Stability of motion. Applications of Lyapunov’s second method to differential systems and equations with delay*. Stanford, CA: Stanford University Press, 1963. Translated from Russian by J. L. Brenner.

- [35] R. Sentis, “Equations différentielles à second membre mesurable,” *Boll. Unione Matematica Italiana*, vol. 5, no. 15-B, pp. 724–742, 1978.
- [36] B. Paden and S. S. Sastry, “A calculus for computing Filippov’s differential inclusion with application to the variable structure control of robot manipulators,” *IEEE Transactions on Circuits and Systems*, vol. 34, no. 1, pp. 73–82, 1987.
- [37] D. Liberzon, *Switching in Systems and Control*. Boston, MA: Birkhäuser, 2003.
- [38] M. di Bernardo, C. J. Budd, A. R. Champneys, and P. Kowalczyk, *Piecewise-smooth Dynamical Systems: Theory and Applications*. New York: Springer Verlag, 2007.
- [39] A. Y. Pogromsky, W. P. M. H. Heemels, and H. Nijmeijer, “On solution concepts and well-posedness of linear relay systems,” *Automatica*, vol. 39, no. 12, pp. 2139–2147, 2003.
- [40] R. M. Colombo and A. Marson, “Hölder continuous o.d.e. related to traffic flow,” *Proceedings of the Royal Society of Edinburgh*, vol. 133A, pp. 759–772, 2003.
- [41] F. H. Clarke, Y. S. Ledyaev, E. D. Sontag, and A. I. Subbotin, “Asymptotic controllability implies feedback stabilization,” *IEEE Transactions on Automatic Control*, vol. 42, no. 10, pp. 1394–1407, 1997.
- [42] R. T. Rockafellar and R. J. B. Wets, *Variational Analysis*. New York: Springer Verlag, 1998.
- [43] J. P. Aubin and H. Frankowska, *Set-Valued Analysis*. Boston, MA: Birkhäuser Verlag, 1990.
- [44] J. Cortés and F. Bullo, “Coordination and geometric optimization via distributed dynamical systems,” *SIAM Journal on Control and Optimization*, vol. 44, no. 5, pp. 1543–1574, 2005.
- [45] J. M. Borwein and A. S. Lewis, *Convex Analysis and Nonlinear Optimization: Theory and Examples*. New York: Springer Verlag, 2000.
- [46] J.-B. Hiriart-Urruty and C. Lemaréchal, *Fundamentals of Convex Analysis*. New York: Springer Verlag, 2nd ed., 2004.
- [47] R. T. Rockafellar, *Convex Analysis*. Princeton, NJ: Princeton University Press, 1970, reprint: 1997.
- [48] F. H. Clarke, Y. S. Ledyaev, and P. R. Wolenski, “Proximal analysis and minimization principles,” *Journal of Mathematical Analysis and Applications*, vol. 196, no. 2, pp. 722–735, 1995.
- [49] J. P. Aubin and I. Ekeland, *Applied Nonlinear Analysis*. New York: John Wiley, 1984.
- [50] H. K. Khalil, *Nonlinear Systems*. Englewood Cliffs, NJ: Prentice Hall, third ed., 2002.
- [51] D. Shevitz and B. Paden, “Lyapunov stability theory of nonsmooth systems,” *IEEE Transactions on Automatic Control*, vol. 39, no. 9, pp. 1910–1914, 1994.
- [52] E. P. Ryan, “An integral invariance principle for differential inclusions with applications in adaptive control,” *SIAM Journal on Control and Optimization*, vol. 36, no. 3, pp. 960–980, 1998.

- [53] A. Bacciotti and F. Ceragioli, “Stability and stabilization of discontinuous systems and nonsmooth Lyapunov functions,” *ESAIM. Control, Optimisation & Calculus of Variations*, vol. 4, pp. 361–376, 1999.
- [54] A. Bacciotti and F. Ceragioli, “Nonpathological Lyapunov functions and discontinuous Caratheodory systems,” *Automatica*, vol. 42, no. 3, pp. 453–458, 2006.
- [55] M. Valadier, “Entraînement unilatéral, lignes de descente, fonctions lipschitziennes non pathologiques,” *C.R. Acad. Sci. Paris Sér. I Math*, vol. 8, pp. 241–244, 1989.
- [56] W. M. Hirsch and S. Smale, *Differential Equations, Dynamical Systems and Linear Algebra*. New York: Academic Press, 1974.
- [57] J. Cortés, “Finite-time convergent gradient flows with applications to network consensus,” *Automatica*, vol. 42, no. 11, pp. 1993–2000, 2006.
- [58] S. Adly, H. Attouch, and A. Cabot, “Finite time stabilization of nonlinear oscillators subject to dry friction,” in *Progresses in Nonsmooth Mechanics and Analysis*, P. Alart, O. Maisonneuve, and R. T. Rockafellar, eds. Dordrecht, The Netherlands: Kluwer Academic Publishers, 2006, pp. 289–304.
- [59] A. Cabot, “Stabilization of oscillators subject to dry friction: Finite time convergence versus exponential decay results,” *Transactions of the American Mathematical Society*, vol. 360, pp. 103–121, 2008.
- [60] R. Olfati-Saber and R. M. Murray, “Consensus problems in networks of agents with switching topology and time-delays,” *IEEE Transactions on Automatic Control*, vol. 49, no. 9, pp. 1520–1533, 2004.
- [61] Z. Artstein, “Stabilization with relaxed controls,” *Nonlinear Analysis*, vol. 7, pp. 1163–1173, 1983.
- [62] F. H. Clarke, Y. S. Ledyaev, and R. J. Stern, “Asymptotic stability and smooth Lyapunov functions,” *Journal of Differential Equations*, vol. 149, pp. 69–114, 1998.
- [63] O. Güler, “Convergence rate estimates for the gradient differential inclusion,” *Optimization Methods and Software*, vol. 20, no. 6, pp. 729–735, 2005.
- [64] R. W. Brockett, “Control theory and singular Riemannian geometry,” in *New Directions in Applied Mathematics*, P. Hilton and G. Young, eds. New York, Springer Verlag, 1982, pp. 11–27.
- [65] E. D. Sontag, “A Lyapunov-like characterization of asymptotic controllability,” *SIAM Journal on Control and Optimization*, vol. 21, pp. 462–471, 1983.
- [66] L. Rifford, “On the existence of nonsmooth control-Lyapunov functions in the sense of generalized gradients,” *ESAIM. Control, Optimisation & Calculus of Variations*, vol. 6, pp. 593–611, 2001.

- [67] G. A. Lafferriere and E. D. Sontag, “Remarks on control Lyapunov functions for discontinuous stabilizing feedback,” in *IEEE Conf. on Decision and Control*, (San Antonio, TX), pp. 306–308, 1993.
- [68] L. Rifford, “Semiconcave control-Lyapunov functions and stabilizing feedbacks,” *SIAM Journal on Control and Optimization*, vol. 41, no. 3, pp. 659–681, 2002.

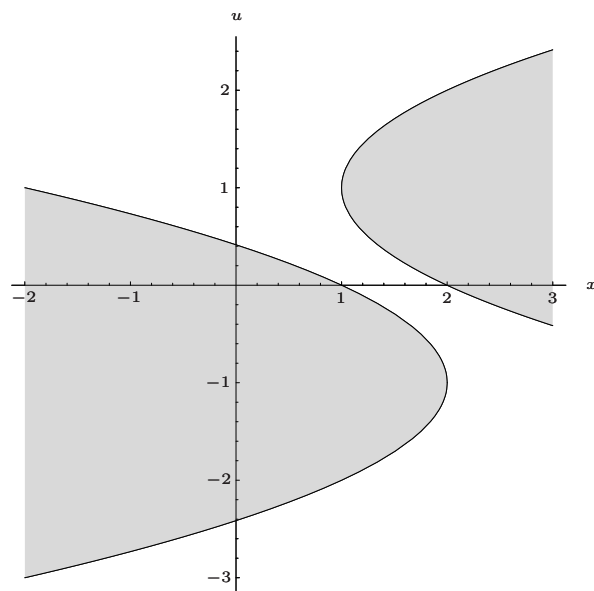

Figure 1. Obstruction to the existence of continuous state-dependent feedback [12]. The shaded areas represent the values of the control u that are needed to stabilize the equilibrium point 0 of system (1). There does not exist a function $x \mapsto u(x)$ defined on \mathbb{R} that at the same time is continuous and belongs to the shaded areas.

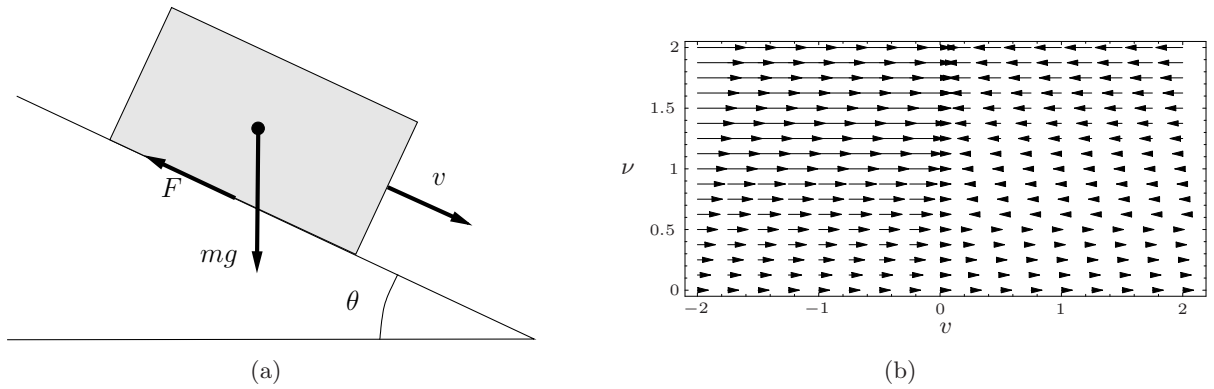

Figure 2. Brick sliding on a frictional ramp. (a) shows the physical quantities used to describe the example. (b) shows the one-dimensional phase portraits of (2) corresponding to values of the friction coefficient ν between 0 and 2, with a ramp inclination of 30 degrees. The phase portrait shows that, for sufficiently small values of ν , every trajectory that starts with positive initial velocity (“moving to the right”) never stops. However, for sufficiently large values of ν , every trajectory that starts with positive initial velocity eventually stops and remains stopped. However, there is no continuously differentiable solution of (2) that exhibits this type of behavior. We thus need to expand our notion of solution beyond continuously differentiable solutions by understanding the effect of the discontinuity in (2).

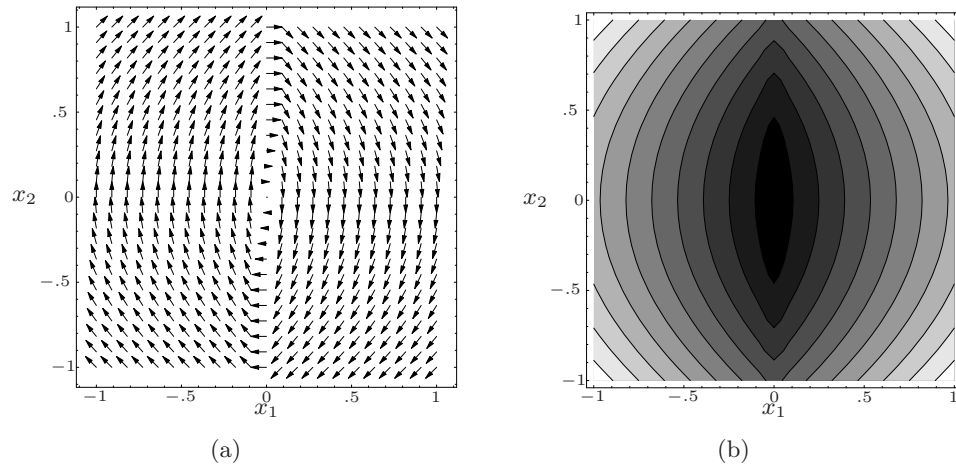

Figure 3. Nonsmooth harmonic oscillator. (a) shows the phase portrait on $[-1, 1]^2$ of the vector field $(x_1, x_2) \mapsto (x_2, -\text{sign}(x_1))$, while (b) shows the contour plot on $[-1, 1]^2$ of the function $(x_1, x_2) \mapsto |x_1| + \frac{x_2^2}{2}$. The discontinuity of the vector field along the x_2 -coordinate axis makes it impossible to find continuously differentiable solutions of (10). On the other hand, the level sets in (b) match the phase portrait in (a) everywhere except for the x_2 -coordinate axis, which suggests that trajectories along the level sets are candidates for solutions of (10) in a sense different from the classical one.

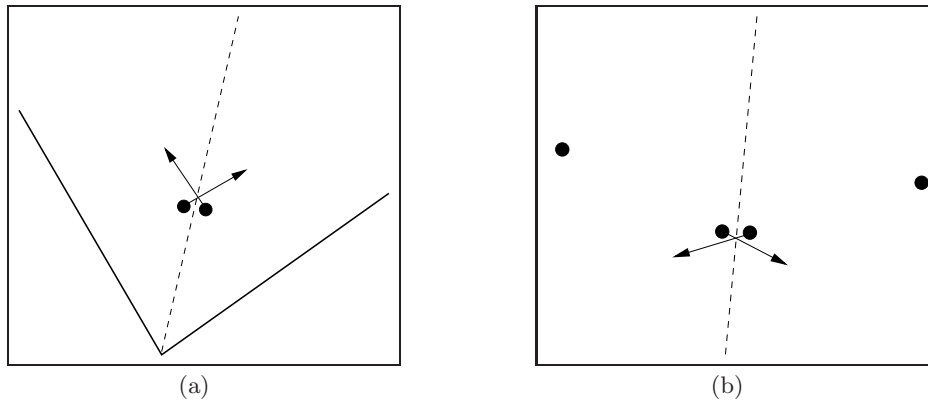

Figure 4. Move-away-from-nearest-neighbor interaction law. A node in (a) computes different directions of motion if placed slightly to the right or to the left of the bisector line defined by two polygonal boundaries. A node in (b) computes different directions of motion if placed slightly to the right or to the left of the half plane defined by two other nodes. In both cases, the vector field is discontinuous.

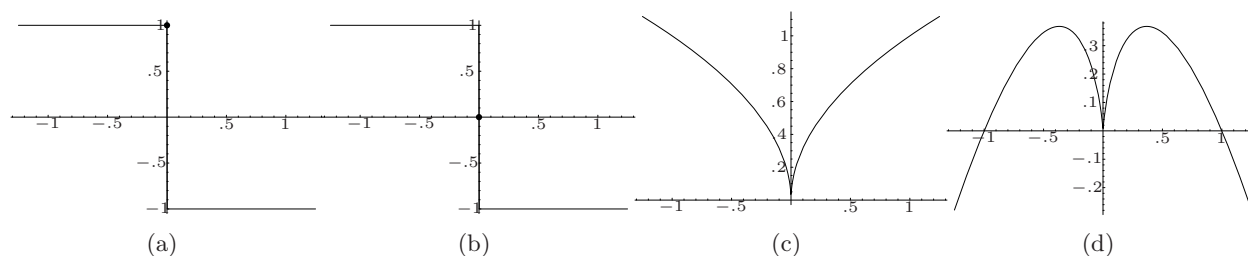

Figure 5. Discontinuous and not-one-sided Lipschitz vector fields. The vector fields in (a) and (b), which differ only in their values at 0, are discontinuous, and thus do not satisfy the hypotheses of Proposition 1. Therefore, the existence of solutions is not guaranteed. In fact, the vector field in (a) has no solution starting from 0, whereas the vector field in (b) has a solution starting from all initial conditions. The vector fields in (c) and (d) are neither locally Lipschitz nor one-sided Lipschitz, and thus do not satisfy the hypotheses of Proposition 2. Therefore, uniqueness of solutions is not guaranteed. The vector field in (c) has two solutions starting from 0. However, the vector field in (d) has a unique solution starting from all initial conditions.

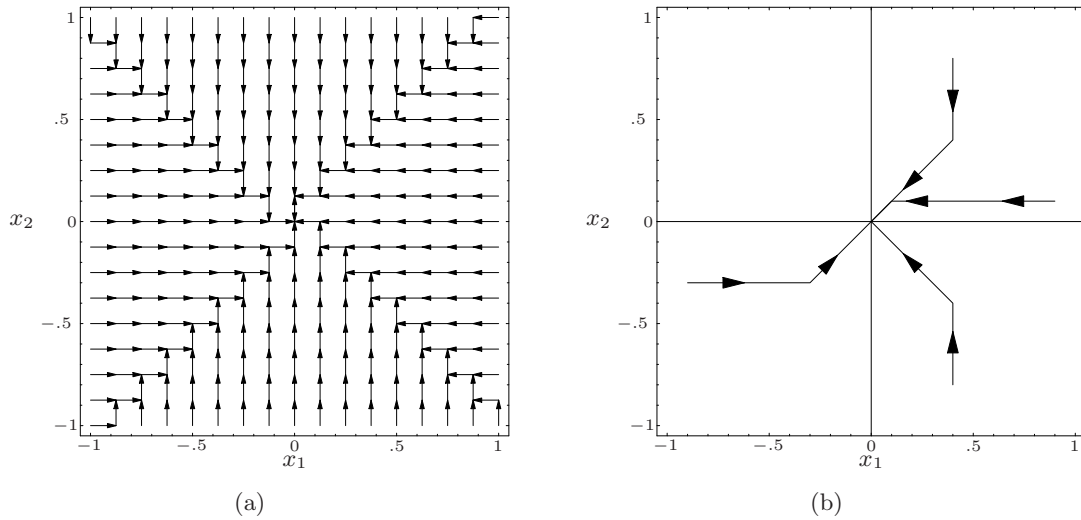

Figure 6. Move-away-from-nearest-neighbor interaction law for one agent moving in the square $[-1, 1]^2 \subset \mathbb{R}^2$. (a) shows the phase portrait, while (b) shows several Filippov solutions. On the diagonals, the vector field pushes trajectories out, whereas, outside the diagonals, the vector field pushes trajectories in. This fact makes it impossible to construct a Caratheodory solution starting from any initial condition on the diagonals of the square.

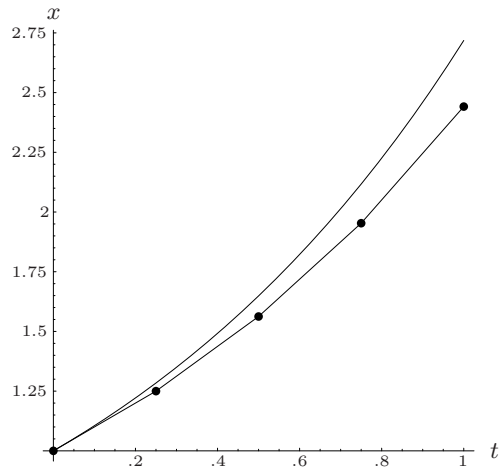

Figure 7. Illustration of the notion of sample-and-hold solution. For the control system $\dot{x} = u$, we choose the control input $u(x) = x$. The upper curve is the classical solution starting from $x_0 = 1$, while the lower curve is the sample-and-hold solution starting from $x_0 = 1$ corresponding to the π -partition $\{0, \frac{1}{4}, \frac{1}{2}, \frac{3}{4}, 1\}$ of $[0, 1]$.

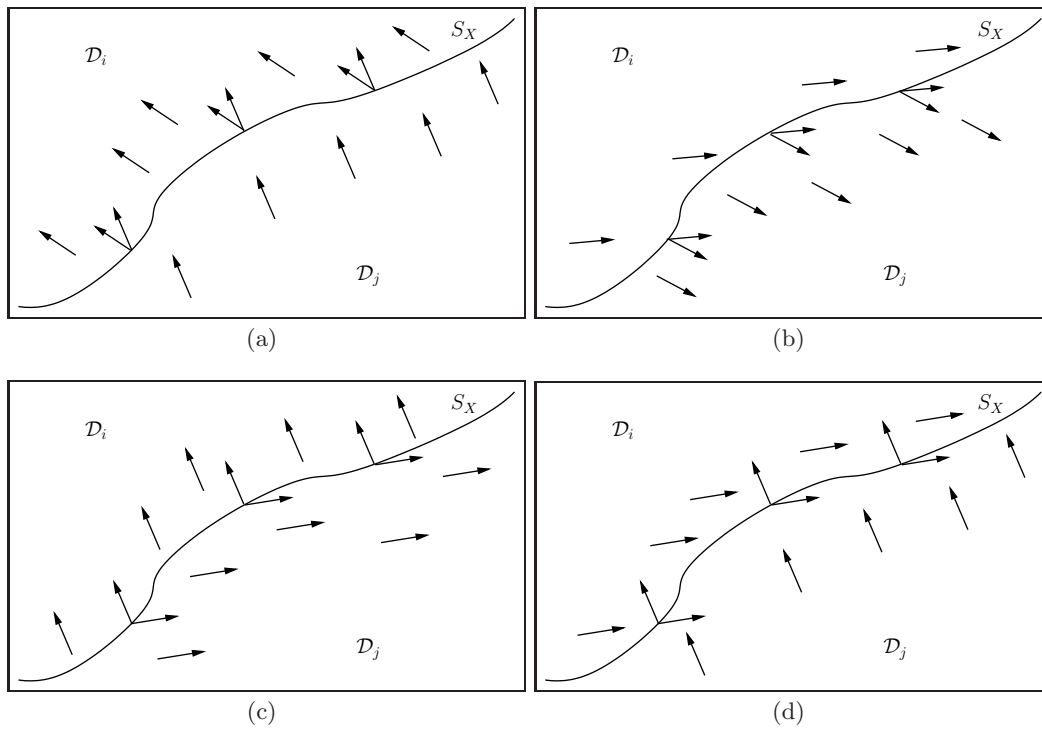

Figure 8. Piecewise continuous vector fields. These dynamical systems are continuous on \mathcal{D}_1 and \mathcal{D}_2 , and discontinuous on S_X . In (a) and (b), Filippov solutions, known as transversally crossing trajectories, cross S_X . In (c), there are two Filippov solutions, known as repulsive trajectories, starting from each point in S_X . Finally, in (d), the Filippov solutions that reach S_X , known as attractive trajectories, continue sliding along S_X .

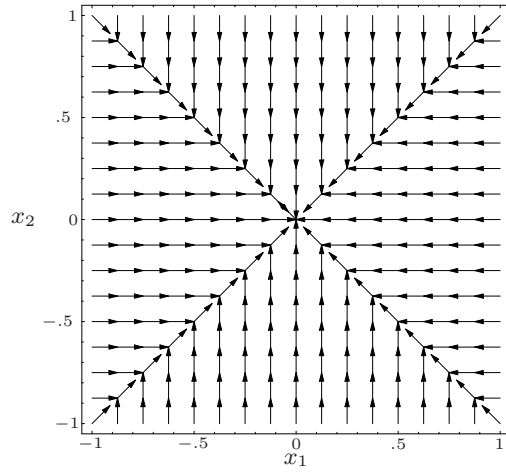

Figure 9. Generalized gradient vector field. This plot shows the generalized gradient vector field of the minimum-distance-to-polygonal-boundary function $\text{sm}_Q : Q \rightarrow \mathbb{R}$ on the square $[-1, 1]^2$. The vector field is discontinuous on the diagonals of the square. Note the similarity with the phase portrait of the move-away-from-nearest-neighbor interaction law for one agent moving in the square $[-1, 1]^2 \subset \mathbb{R}^2$ plotted in Figure 6.

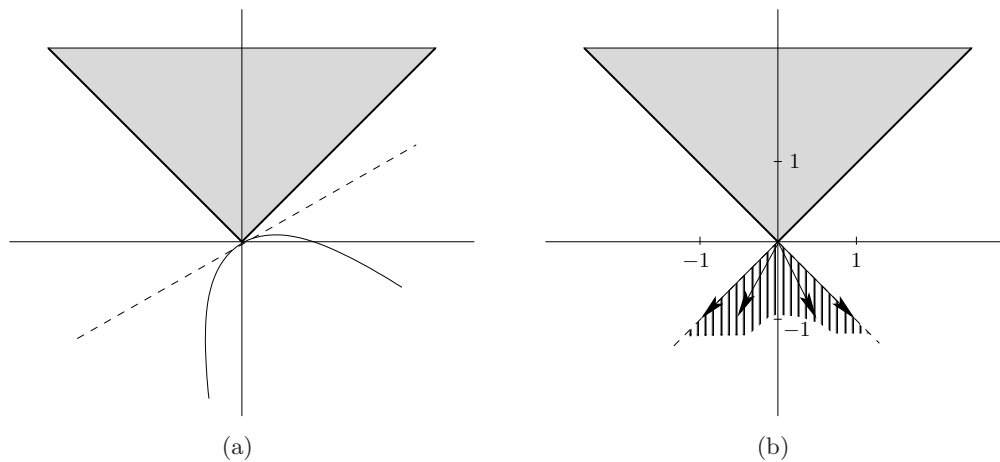

Figure 10. Geometric interpretations of the proximal subdifferential of the function $x \mapsto |x|$ at $x = 0$ computed in Example 17. The epigraph of the function is shaded, while the proximal normal cone to the epigraph at 0 is striped. In (a), according to (51), each proximal subgradient corresponds to a direction tangent to a parabola that fits under the epigraph of the function. In (b), according to (52), each proximal subgradient can be uniquely associated with an element of the proximal normal cone to the epigraph of the function.

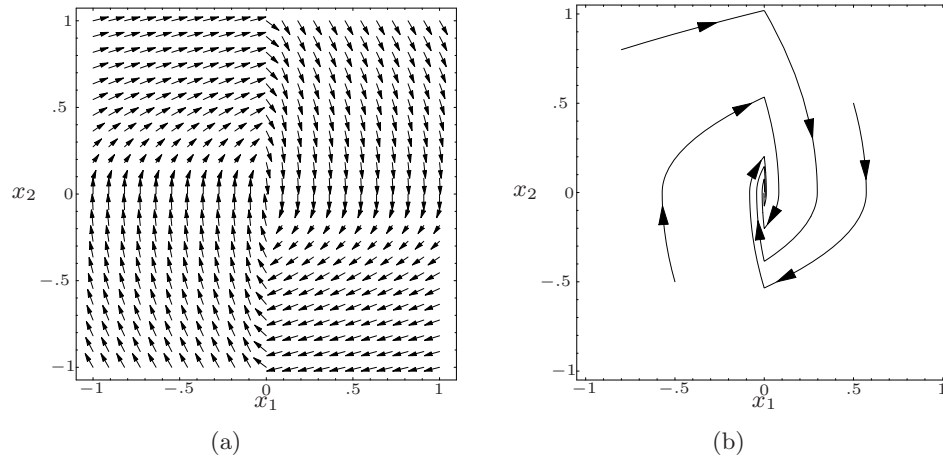

Figure 11. Nonsmooth harmonic oscillator with dissipation. (a) shows the phase portrait on $[-1, 1]^2$ of the vector field $(x_1, x_2) \mapsto (x_2, -\text{sign}(x_1) - k \text{sign}(x_2))$, where $k = 0.75$, while (b) shows some Filippov solutions of the associated dynamical system (10). In the nonsmooth harmonic oscillator in Example 3, the equilibrium at the origin is strongly stable, but not strongly asymptotically stable, see Figure 3. The addition of dissipation renders the equilibrium at the origin strongly asymptotically stable.

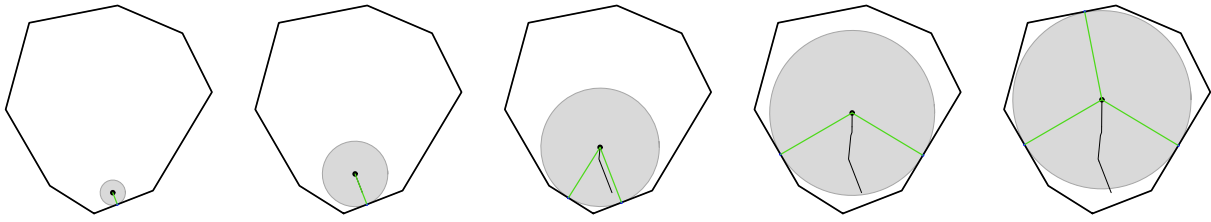

Figure 12. From left to right, evolution of the nonsmooth gradient flow of the function $-sm_Q$ in a convex polygon. At each snapshot, the value of sm_Q is the radius of the largest disk (plotted in gray) contained in the polygon with center at the current location. The flow converges in finite time to the incenter set, which, for this polygon, is a singleton whose only element is the center of the disk in the rightmost snapshot.

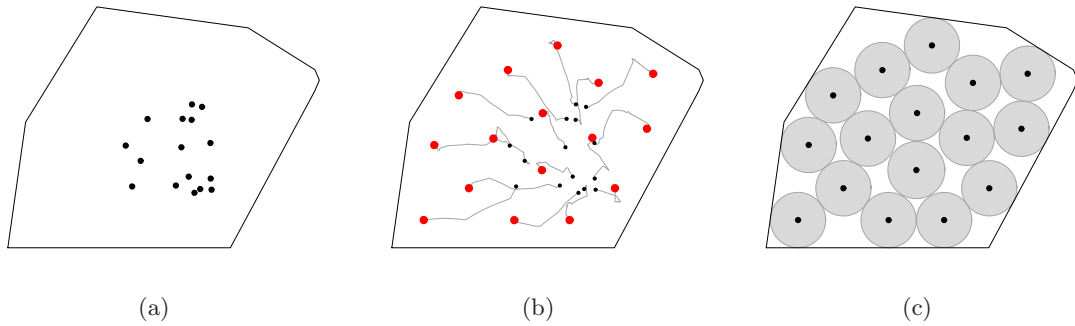

Figure 13. The move-away-from-nearest-neighbor interaction law for solving a sphere-packing problem within the polygon Q . (a) is the initial configuration, (b) is the evolution, and (c) is the final configuration of a Filippov solution. In (c), the minimum radius of the shaded spheres corresponds to the value of the locally Lipschitz function \mathcal{H}_{SP} , defined in (69). The Filippov solutions of the move-away-from-nearest-neighbor dynamical system monotonically increase the value of \mathcal{H}_{SP} . In (c), every node is at equilibrium since the infinitesimal motion of a node in any direction would place it closer to at least another node. This discontinuous dynamical system is an example of how simple local interactions can achieve a global objective.

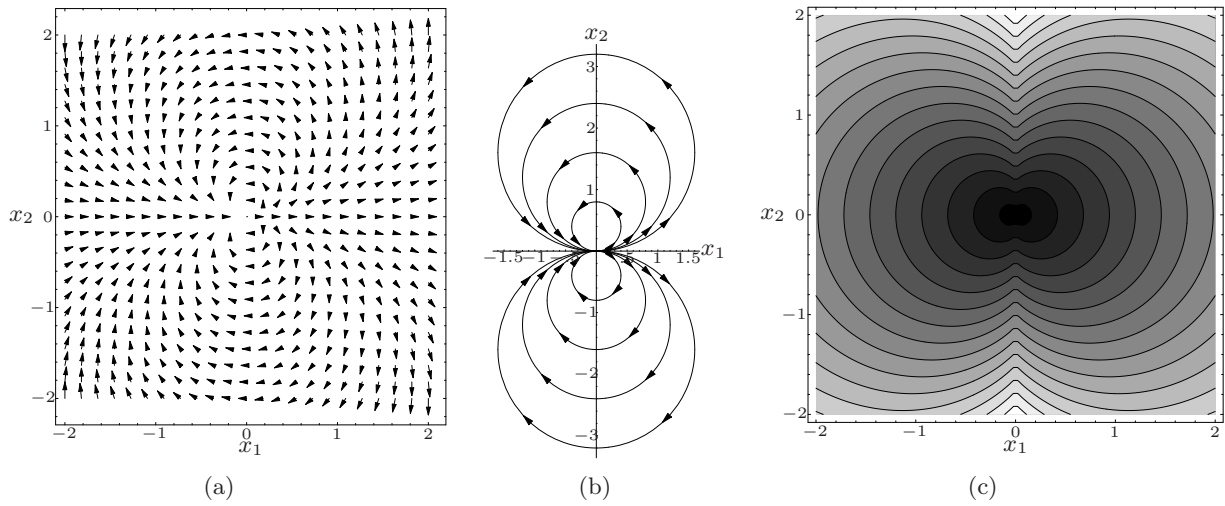

Figure 14. Cart on a circle. (a) shows the phase portrait of the input vector field $(x_1, x_2) \mapsto (x_1^2 - x_2^2, 2x_1x_2)$, (b) shows its integral curves, and (c) shows the contour plot of the function $0 \neq (x_1, x_2) \mapsto \frac{x_1^2 + x_2^2}{\sqrt{x_1^2 + x_2^2} + |x_1|}$, $(0, 0) \mapsto 0$. The origin cannot be asymptotically stabilized by means of continuous feedback in the cart dynamics (72)-(73). However, the origin can be asymptotically stabilized by means of discontinuous feedback when solutions are understood in the sample-and-hold sense.

Sidebar 1: Solutions with Jumps

In this article, we focus entirely on absolutely continuous solutions of ordinary differential equations. However, nonsmooth continuous-time systems can possess discontinuous solutions that admit jumps in the state. Such notions are appropriate for dealing with, for instance, mechanical systems subject to unilateral constraints [15]. As an example, a bouncing ball hitting the ground experiences an instantaneous change of velocity. This change corresponds to a discontinuous jump in the trajectory describing the evolution of the velocity of the ball. Both measure differential inclusions [S1, S2] and linear complementarity systems [S3, S4, S5, S6] are approaches that specifically allow for discontinuous solutions. Within hybrid systems theory [S7, S8, S9, S10], discontinuous solutions arise in systems that involve both continuous- and discrete-time evolutions.

References

- [S1] J.-J. Moreau, “Unilateral contact and dry friction in finite freedom dynamics,” in *Non-smooth Mechanics and Applications*, J.-J. Moreau and P. D. Panagiotopoulos, eds. New York: Springer Verlag, 1988, vol. 302, pp. 1–82.
- [S2] M. D. P. M. Marques, *Differential Inclusions in Nonsmooth Mechanical Problems: Shocks and Dry Friction*. Boston, MA: Birkhäuser Verlag, 1993.
- [S3] R. W. Cottle, J.-S. Pang, and R. E. Stone, *The Linear Complementarity Problem*. New York: Academic Press, 1992.
- [S4] G. Isac, *Complementarity problems*. New York: Springer Verlag, 1992.
- [S5] M. C. Ferris and J.-S. Pang, “Engineering and economic applications of complementarity problems,” *SIAM Review*, vol. 39, no. 4, pp. 669–713, 1997.
- [S6] B. Brogliato, “Some perspectives on the analysis and control of complementarity systems,” *IEEE Transactions on Automatic Control*, vol. 48, no. 6, pp. 918–935, 2003.
- [S7] P. J. Antsaklis and A. Nerode (guest eds.), “Special issue on hybrid control systems,” *IEEE Transactions on Automatic Control*, vol. 43, no. 4, 1998.
- [S8] A. S. Morse, C. C. Pantelides, S. S. Sastry, and J. M. Schumacher (guest eds.), “Special issue on hybrid systems,” *Automatica*, vol. 35, no. 3, 1999.
- [S9] A. J. van der Schaft and H. Schumacher, *An Introduction to Hybrid Dynamical Systems*. New York: Springer Verlag, 2000.
- [S10] R. Goebel and A. R. Teel, “Solutions of hybrid inclusions via set and graphical convergence with stability theory applications,” *Automatica*, vol. 42, no. 4, pp. 573–587, 2006.

Sidebar 2: Additional Solution Notions for Discontinuous Systems

Several solution notions are available in addition to Caratheodory, Filippov, and sample-and-hold solutions. These notions include the ones considered by Krasovskii [34], Hermes [S11, S12], Ambrosio [S13], Sentis [35], and Yakubovich-Leonov-Gelig [S14], see Table S1. As in the case in which the vector field is continuous, Euler solutions [18, 24] are useful for establishing existence and in characterizing basic mathematical properties of the dynamical system. Additional notions of solutions for discontinuous systems are provided in [S14, Section 1.1.3]. With so many notions of solution available, various works explore the relationships among them. For example, Caratheodory and Filippov solutions are compared in [S15]; Caratheodory and Krasovskii solutions are compared in [S16]; Caratheodory, Euler, sample-and-hold, Filippov, and Krasovskii solutions are compared in [16]; Hermes, Filippov, and Krasovskii solutions are compared in [S12]; and Caratheodory, Euler, and Sentis solutions are compared in [S17].

Notion of solution	References
Caratheodory	[18]
Filippov	[18]
Krasovskii	[34]
Euler	[18, 24]
Sample-and-hold	[23]
Hermes	[S11, S12]
Sentis	[35], [S17]
Ambrosio	[S13]
Yakubovich-Leonov-Gelig	[S14]

Table S1. Several notions of solution for discontinuous dynamics. Depending on the specific problem, some notions give more physically meaningful solution trajectories than others.

References

- [S11] H. Hermes, “Discontinuous vector fields and feedback control,” in *Differential Equations and Dynamical Systems*. New York: Academic Press, 1967, pp. 155–165.
- [S12] O. Hájek, “Discontinuous differential equations I,” *Journal of Differential Equations*, vol. 32, pp. 149–170, 1979.
- [S13] L. Ambrosio, “A lower closure theorem for autonomous orientor fields,” *Proc. R. Soc. Edin.*, vol. A110, no. 3/4, pp. 249–254, 1988.
- [S14] V. A. Yakubovich, G. A. Leonov, and A. K. Gelig, *Stability of Stationary Sets in Control Systems With Discontinuous Nonlinearities*. Singapore: World Scientific Publishing, 2004, vol. 14.
- [S15] J. S. Spraker and D. C. Biles, “A comparison of the Caratheodory and Filippov solution sets,” *Journal of Mathematical Analysis and Applications*, vol. 198, no. 2, pp. 571–580, 1996.
- [S16] S. Hu, “Differential equations with discontinuous right-hand sides,” *Journal of Mathematical Analysis and Applications*, vol. 154, no. 2, pp. 377–390, 1991.

- [S17] A. Bacciotti, “Some remarks on generalized solutions of discontinuous differential equations,”
International Journal of Pure and Applied Mathematics, vol. 10, no. 3, pp. 257–266, 2004.

Sidebar 3: Additional Topics on Discontinuous Systems and Differential Inclusions

Beyond the topics discussed in this article, we briefly mention several that are relevant to systems and control. These topics include continuous dependence of solutions with respect to initial conditions and parameters [18, 19], robustness properties against external disturbances and state measurement errors [24] and [S18], conditions for the existence of periodic solutions [18, 20], bifurcations [38], converse Lyapunov theorems [S19, S20], controllability of differential inclusions [20, 24], output tracking in differential inclusions [43], systems subject to gradient nonlinearities [S14], viability theory [S21], maximal monotone inclusions [19], projected dynamical systems and variational inequalities [S22], and numerical methods for discontinuous systems and differential inclusions [S23, S24, S25]. Several works report equivalence results among different approaches to nonsmooth systems, including [19] on the equivalence between differential inclusions and projected dynamical systems, and [S26] on the equivalence of these formalisms with complementarity systems.

References

- [S18] Y. S. Ledyaev and E. D. Sontag, “A Lyapunov characterization of robust stabilization,” *Nonlinear Analysis, Theory, Methods, and Applications*, vol. 37, pp. 813–840, 1999.
- [S19] F. H. Clarke, Y. S. Ledyaev, L. Rifford, and R. J. Stern, “Feedback stabilization and Lyapunov functions,” *SIAM Journal on Control and Optimization*, vol. 39, no. 1, pp. 25–48, 2000.
- [S20] A. R. Teel and L. Praly, “A smooth Lyapunov function from a class KL estimate involving two positive semidefinite functions,” *ESAIM J. Control, Optimization and Calculus of Variations*, vol. 5, pp. 313–367, 2000.
- [S21] J. P. Aubin, *Viability Theory*. Boston, MA: Birkhäuser Verlag, 1991.
- [S22] A. Nagurney and D. Zhang, *Projected Dynamical Systems and Variational Inequalities with Applications*. Dordrecht, The Netherlands: Kluwer Academic Publishers, 1996.
- [S23] A. Dontchev and F. Lempio, “Difference methods for differential inclusions: A survey,” *SIAM Review*, vol. 34, pp. 263–294, 1992.
- [S24] F. Lempio and V. Veliov, “Discrete approximations of differential inclusions,” *Bayreuth. Math. Schr.*, vol. 54, pp. 149–232, 1998.
- [S25] V. Acary and B. Brogliato, *Numerical Methods for Nonsmooth Dynamical Systems: Applications in Mechanics and Electronics*. New York: Springer Verlag, 2008.
- [S26] B. Brogliato, A. Daniilidis, C. Lemaréchal, and V. Acary, “On the equivalence between complementarity systems, projected systems, and differential inclusions,” *Systems & Control Letters*, vol. 55, no. 1, pp. 45–51, 2006.

Sidebar 4: Index of Symbols

The following is a list of the symbols used throughout the article.

Symbol	: Description and page(s) when applicable
$G[X]$: Set-valued map associated with a control system $X : \mathbb{R}^d \times \mathcal{U} \rightarrow \mathbb{R}^d$
$\overline{\text{co}}(S)$: Convex closure of a set $S \subseteq \mathbb{R}^d$
$\text{co}(S)$: Convex hull of a set $S \subseteq \mathbb{R}^d$
$\text{diam}(\pi)$: Diameter of the partition π
$f^o(x; v)$: Generalized directional derivative of the function $f : \mathbb{R}^d \rightarrow \mathbb{R}$ at $x \in \mathbb{R}^d$ in the direction of $v \in \mathbb{R}^d$
$f'(x; v)$: Right directional derivative of the function $f : \mathbb{R}^d \rightarrow \mathbb{R}$ at $x \in \mathbb{R}^d$ in the direction of $v \in \mathbb{R}^d$
S_X	: Set of points where the vector field $X : \mathbb{R}^d \rightarrow \mathbb{R}^d$ is discontinuous
$\text{dist}(p, S)$: Euclidean distance from the point $p \in \mathbb{R}^d$ to the set $S \subseteq \mathbb{R}^d$
$F[X]$: Filippov set-valued map associated with a vector field $X : \mathbb{R}^d \rightarrow \mathbb{R}^d$
∂f	: Generalized gradient of the locally Lipschitz function $f : \mathbb{R}^d \rightarrow \mathbb{R}$
∇f	: Gradient of the differentiable function $f : \mathbb{R}^d \rightarrow \mathbb{R}$
$\text{Ln}(S)$: Least-norm elements in the closure of the set $S \subseteq \mathbb{R}^d$
$\Omega(x)$: Set of limit points of a curve $t \mapsto x(t)$
\mathcal{N}	: Nearest-neighbor map
n_e	: Unit normal to the edge e of a polygon Q pointing toward the interior of Q
Ω_f	: Set of points where the locally Lipschitz function $f : \mathbb{R}^d \rightarrow \mathbb{R}$ fails to be differentiable
π	: Partition of a closed interval
$\mathfrak{B}(S)$: Set whose elements are all the possible subsets of $S \subseteq \mathbb{R}^d$
$\partial_P f$: Proximal subdifferential of the lower semicontinuous function $f : \mathbb{R}^d \rightarrow \mathbb{R}$
$\tilde{\mathcal{L}}_{\mathcal{F}} f$: Set-valued Lie derivative of the locally Lipschitz function $f : \mathbb{R}^d \rightarrow \mathbb{R}$ with respect to the set-valued map $\mathcal{F} : \mathbb{R}^d \rightarrow \mathfrak{B}(\mathbb{R}^d)$
$\tilde{\mathcal{L}}_X f$: Set-valued Lie derivative of the locally Lipschitz function $f : \mathbb{R}^d \rightarrow \mathbb{R}$ with respect to the Filippov set-valued map $F[X] : \mathbb{R}^d \rightarrow \mathfrak{B}(\mathbb{R}^d)$
$\underline{\mathcal{L}}_{\mathcal{F}} f$: Lower set-valued Lie derivative of the lower semicontinuous function $f : \mathbb{R}^d \rightarrow \mathbb{R}$ with respect to the set-valued map $\mathcal{F} : \mathbb{R}^d \rightarrow \mathfrak{B}(\mathbb{R}^d)$
$\overline{\mathcal{L}}_{\mathcal{F}} f$: Upper set-valued Lie derivative of the lower semicontinuous function $f : \mathbb{R}^d \rightarrow \mathbb{R}$ with respect to the set-valued map $\mathcal{F} : \mathbb{R}^d \rightarrow \mathfrak{B}(\mathbb{R}^d)$
\mathcal{F}	: Set-valued map
sm_Q	: Minimum distance function from a point in a convex polygon $Q \subset \mathbb{R}^d$ to the boundary of Q

Sidebar 5: Locally Lipschitz Functions

A function $f : \mathbb{R}^d \rightarrow \mathbb{R}^m$ is *locally Lipschitz at* $x \in \mathbb{R}^d$ if there exist $L_x, \varepsilon \in (0, \infty)$ such that

$$\|f(y) - f(y')\|_2 \leq L_x \|y - y'\|_2,$$

for all $y, y' \in B(x, \varepsilon)$. A function that is locally Lipschitz at x is continuous at x , but the converse is not true. For example, $f : \mathbb{R} \rightarrow \mathbb{R}$, $f(x) = \sqrt{|x|}$, is continuous at 0, but not locally Lipschitz at 0, see Figure S1(a). A function is *locally Lipschitz on* $S \subseteq \mathbb{R}^d$ if it is locally Lipschitz at x for

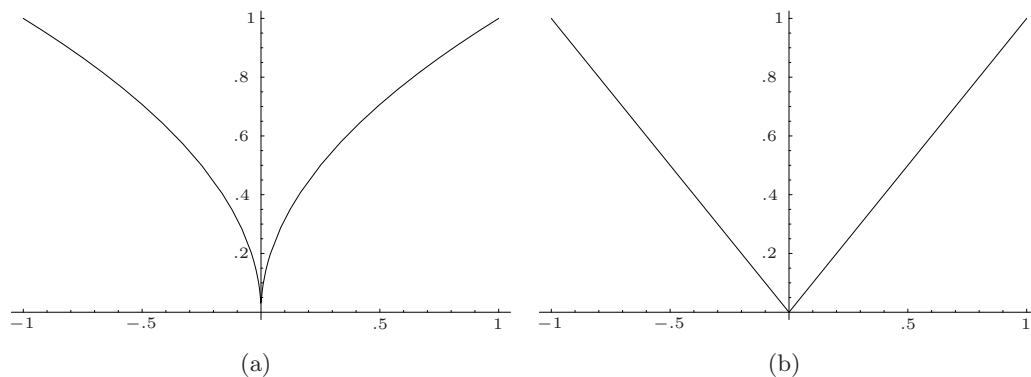

Figure S1. Illustration of the difference among continuous, locally Lipschitz, and differentiable functions. (a) shows the graph of $f : \mathbb{R} \rightarrow \mathbb{R}$, $f(x) = \sqrt{|x|}$, which is continuous at 0, but not locally Lipschitz at 0. (b) shows the graph of $f : \mathbb{R} \rightarrow \mathbb{R}$, $f(x) = |x|$, which is locally Lipschitz at 0, but not differentiable at 0.

all $x \in S$. If f is locally Lipschitz on \mathbb{R}^d , we simply say f is locally Lipschitz. Convex functions are locally Lipschitz [S27], and hence concave functions are also locally Lipschitz. Note that a function that is continuously differentiable at x is locally Lipschitz at x , but the converse is not true. For example, $f : \mathbb{R} \rightarrow \mathbb{R}$, $f(x) = |x|$, is locally Lipschitz at 0, but not differentiable at 0, see Figure S1(b). A function $f : \mathbb{R} \times \mathbb{R}^d \rightarrow \mathbb{R}^m$ that depends explicitly on time is *locally Lipschitz at* $x \in \mathbb{R}^d$ if there exists $\varepsilon \in (0, \infty)$ and $L_x : \mathbb{R} \rightarrow (0, \infty)$ such that $\|f(t, y) - f(t, y')\|_2 \leq L_x(t) \|y - y'\|_2$ for all $t \in \mathbb{R}$ and $y, y' \in B(x, \varepsilon)$.

References

- [S27] Department of Mathematics, Wayne State University, “Every convex function is locally Lipschitz,” *The American Mathematical Monthly*, vol. 79, no. 10, pp. 1121–1124, 1972.

Sidebar 6: Caratheodory Conditions for Time-varying Vector Fields

Consider the differential equation

$$\dot{x}(t) = X(t, x(t)), \tag{S1}$$

where $X : [0, \infty) \times \mathbb{R}^d \rightarrow \mathbb{R}^d$ is a time-varying vector field. The following result is taken from [18]: a weaker version of the Caratheodory conditions is given, for instance, in [S28].

Proposition S1. *Let $X : [0, \infty) \times \mathbb{R}^d \rightarrow \mathbb{R}^d$. Assume that (i) for almost all $t \in [0, \infty)$, the map $x \mapsto X(t, x)$ is continuous, (ii) for each $x \in \mathbb{R}^d$, the map $t \mapsto X(t, x)$ is measurable, and (iii) X is locally essentially bounded, that is, for all $(t, x) \in [0, \infty) \times \mathbb{R}^d$, there exist $\varepsilon \in (0, \infty)$ and an integrable function $m : [t, t + \delta] \rightarrow (0, \infty)$ such that $\|X(s, y)\|_2 \leq m(s)$ for almost all $s \in [t, t + \delta]$ and all $y \in B(x, \varepsilon)$. Then, for all $(t_0, x_0) \in [0, \infty) \times \mathbb{R}^d$, there exists a Caratheodory solution of (S1) with initial condition $x(t_0) = x_0$.*

The specialization of Proposition S1 to a time-invariant vector field requires that the vector field be continuous, which in turn guarantees the existence of a classical solution.

References

- [S28] D. C. Biles and P. A. Binding, “On Caratheodory’s conditions for the initial value problem,” *Proceedings of the American Mathematical Society*, vol. 125, no. 5, pp. 1371–1376, 1997.

Sidebar 7: Set-valued Maps

A set-valued map, as its name suggests, is a map that assigns sets to points. We consider time-varying set-valued maps of the form $\mathcal{F} : [0, \infty) \times \mathbb{R}^d \rightarrow \mathfrak{B}(\mathbb{R}^d)$. Recall that $\mathfrak{B}(\mathbb{R}^d)$ denotes the collection of all subsets of \mathbb{R}^d . The map \mathcal{F} assigns to each point $(t, x) \in [0, \infty) \times \mathbb{R}^d$ the set $\mathcal{F}(t, x) \subseteq \mathbb{R}^d$. Note that a standard map $f : [0, \infty) \times \mathbb{R}^d \rightarrow \mathbb{R}^d$ can be interpreted as a singleton-valued map. A complete analysis for set-valued maps can be developed, as in the case of standard maps [43]. Here, we are mainly interested in concepts related to boundedness and continuity, which we define next.

The set-valued map $\mathcal{F} : [0, \infty) \times \mathbb{R}^d \rightarrow \mathfrak{B}(\mathbb{R}^d)$ is *locally bounded* (respectively, *locally essentially bounded*) at $(t, x) \in [0, \infty) \times \mathbb{R}^d$ if there exist $\varepsilon, \delta \in (0, \infty)$ and an integrable function $m : [t, t + \delta] \rightarrow (0, \infty)$ such that $\|z\|_2 \leq m(s)$ for all $z \in \mathcal{F}(s, y)$, all $s \in [t, t + \delta]$, and all $y \in B(x, \varepsilon)$ (respectively, almost all $y \in B(x, \varepsilon)$ in the sense of Lebesgue measure).

The time-invariant set-valued map $\mathcal{F} : \mathbb{R}^d \rightarrow \mathfrak{B}(\mathbb{R}^d)$ is *upper semicontinuous* (respectively, *lower semicontinuous*) at $x \in \mathbb{R}^d$ if, for all $\varepsilon \in (0, \infty)$, there exists $\delta \in (0, \infty)$ such that $\mathcal{F}(y) \subseteq \mathcal{F}(x) + B(0, \varepsilon)$ (respectively, $\mathcal{F}(x) \subseteq \mathcal{F}(y) + B(0, \varepsilon)$) for all $y \in B(x, \delta)$. The set-valued map $\mathcal{F} : \mathbb{R}^d \rightarrow \mathfrak{B}(\mathbb{R}^d)$ is *continuous* at $x \in \mathbb{R}^d$ if it is both upper and lower semicontinuous at $x \in \mathbb{R}^d$. Finally, the set-valued map $\mathcal{F} : \mathbb{R}^d \rightarrow \mathfrak{B}(\mathbb{R}^d)$ is *locally Lipschitz* at $x \in \mathbb{R}^d$ if there exist $L_x, \varepsilon \in (0, \infty)$ such that

$$\mathcal{F}(y') \subseteq \mathcal{F}(y) + L_x \|y - y'\|_2 \overline{B}(0, 1),$$

for all $y, y' \in B(x, \varepsilon)$. A locally Lipschitz set-valued map at x is upper semicontinuous at x , but the converse is not true.

The notion of upper semicontinuity of a map $f : \mathbb{R}^d \rightarrow \mathbb{R}$, which is defined in the section “The proximal subdifferential of a lower semicontinuous function,” is weaker than the notion of upper semicontinuity of f when viewed as a (singleton-valued) set-valued map from \mathbb{R}^d to $\mathfrak{B}(\mathbb{R})$. Indeed, the latter is equivalent to the condition that $f : \mathbb{R}^d \rightarrow \mathbb{R}$ is continuous.

Sidebar 8: Caratheodory Solutions of Differential Inclusions

A differential inclusion [19, 20] is a generalization of a differential equation. At each state, a differential inclusion specifies a set of possible evolutions, rather than a single one. This object is defined by means of a set-valued map, see “Set-valued Maps.” The *differential inclusion* associated with a time-varying set-valued map $\mathcal{F} : [0, \infty) \times \mathbb{R}^d \rightarrow \mathfrak{B}(\mathbb{R}^d)$ is an equation of the form

$$\dot{x}(t) \in \mathcal{F}(t, x(t)). \quad (\text{S1})$$

The point $x_e \in \mathbb{R}^d$ is an *equilibrium* of the differential inclusion if $0 \in \mathcal{F}(t, x_e)$ for all $t \in [0, \infty)$. We now define the notion of solution of a differential inclusion in the sense of Caratheodory.

A *Caratheodory solution* of (S1) defined on $[t_0, t_1] \subset [0, \infty)$ is an absolutely continuous map $x : [t_0, t_1] \rightarrow \mathbb{R}^d$ such that $\dot{x}(t) \in \mathcal{F}(t, x(t))$ for almost every $t \in [t_0, t_1]$. The existence of at least one solution starting from each initial condition is guaranteed by the following result (see, for instance, [14, 19]).

Proposition S1. *Let $\mathcal{F} : [0, \infty) \times \mathbb{R}^d \rightarrow \mathfrak{B}(\mathbb{R}^d)$ be locally bounded and take nonempty, compact, and convex values. Assume that, for each $t \in \mathbb{R}$, the set-valued map $x \mapsto \mathcal{F}(t, x)$ is upper semicontinuous, and, for each $x \in \mathbb{R}^d$, the set-valued map $t \mapsto \mathcal{F}(t, x)$ is measurable. Then, for all $(t_0, x_0) \in [0, \infty) \times \mathbb{R}^d$, there exists a Caratheodory solution of (S1) with initial condition $x(t_0) = x_0$.*

This result is sufficient for our purposes. Additional existence results based on alternative assumptions are given in [14, 24]. The uniqueness of Caratheodory solutions is guaranteed by the following result.

Proposition S2. *In addition to the hypotheses of Proposition S1, assume that, for all $x \in \mathbb{R}^d$, there exist $\varepsilon \in (0, \infty)$ and an integrable function $L_x : \mathbb{R} \rightarrow (0, \infty)$ such that*

$$(v - w)^T(y - y') \leq L_x(t) \|y - y'\|_2^2, \quad (\text{S2})$$

for almost every $y, y' \in B(x, \varepsilon)$, every $t \in [0, \infty)$, every $v \in \mathcal{F}(t, y)$, and every $w \in \mathcal{F}(t, y')$. Then, for all $(t_0, x_0) \in [0, \infty) \times \mathbb{R}^d$, there exists a unique Caratheodory solution of (S1) with initial condition $x(t_0) = x_0$.

The following example illustrates propositions S1 and S2. Following [43], consider the set-valued map $\mathcal{F} : \mathbb{R} \rightarrow \mathfrak{B}(\mathbb{R})$ defined by

$$\mathcal{F}(x) = \begin{cases} 0, & x \neq 0, \\ [-1, 1], & x = 0. \end{cases}$$

Note that \mathcal{F} is upper semicontinuous, but not lower semicontinuous, and thus it is not continuous. This set-valued map satisfies all of the hypotheses in Proposition S1, and therefore Caratheodory solutions exist starting from all initial conditions. In addition, \mathcal{F} satisfies (S2) as long as y and y' are nonzero. Therefore, Proposition S2 guarantees the uniqueness of Caratheodory solutions. In fact, for every initial condition, the Caratheodory solution of $\dot{x}(t) \in \mathcal{F}(x(t))$ is just the equilibrium solution.

Sidebar 9: Uniqueness of Filippov Solutions of Piecewise Continuous Vector Fields

Here we justify why, in order to guarantee the uniqueness of Filippov solutions for a piecewise continuous vector field, we cannot resort to Proposition 4 and instead must use Proposition 5. To see this, consider a piecewise continuous vector field $X : \mathbb{R}^d \rightarrow \mathbb{R}^d$, $d \geq 2$, and let $x \in S_X$ be a point of discontinuity. Let us show that X is not essentially one-sided Lipschitz on every neighborhood of x . For simplicity, assume x belongs to the boundaries of just two sets, that is, $x \in \text{bdry}(\mathcal{D}_i) \cap \text{bdry}(\mathcal{D}_j)$ (the argument proceeds similarly for the general case). For $\varepsilon > 0$, we show that (32) is violated on a set of nonzero measure contained in $B(x, \varepsilon)$. Notice that

$$(X(y) - X(y'))^T(y - y') = \|X(y) - X(y')\|_2 \|y - y'\|_2 \cos \alpha(y, y'),$$

where $\alpha(y, y') = \angle(X(y) - X(y'), y - y')$ is the angle between the vectors $X(y) - X(y')$ and $y - y'$. Therefore, (32) is equivalent to

$$\|X(y) - X(y')\|_2 \cos \alpha(y, y') \leq L \|y - y'\|_2. \quad (\text{S3})$$

Consider the vectors $X|_{\overline{\mathcal{D}_i}}(x)$ and $X|_{\overline{\mathcal{D}_j}}(x)$. Since X is discontinuous at x , we have $X|_{\overline{\mathcal{D}_i}}(x) \neq X|_{\overline{\mathcal{D}_j}}(x)$. Take $y \in \mathcal{D}_i \cap B(x, \varepsilon)$ and $y' \in \mathcal{D}_j \cap B(x, \varepsilon)$. Note that, as y and y' tend to x , the vector $X(y) - X(y')$ tends to $X|_{\overline{\mathcal{D}_i}}(x) - X|_{\overline{\mathcal{D}_j}}(x)$. Consider then the straight line ℓ that crosses S_X , passes through x , and forms a small angle $\beta > 0$ with $X|_{\overline{\mathcal{D}_i}}(x) - X|_{\overline{\mathcal{D}_j}}(x)$, see Figure S2.

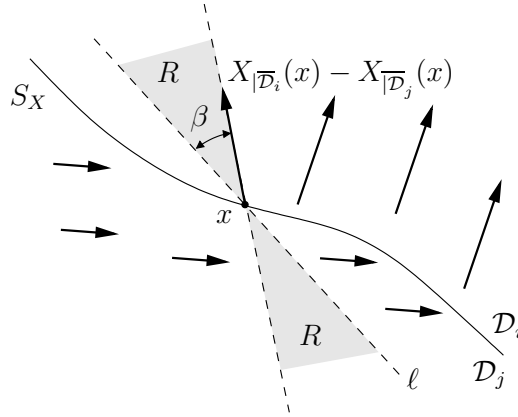

Figure S2. Piecewise continuous vector field. The vector field has a unique Filippov solution starting from all initial conditions. Note that solutions that reach S_X coming from \mathcal{D}_j cross it, and then continue in \mathcal{D}_i . However, the vector field is not essentially one-sided Lipschitz, and hence Proposition 4 cannot be invoked to conclude uniqueness.

Let R be the set enclosed by the line ℓ and the line in the direction of the vector $X|_{\overline{\mathcal{D}_i}}(x) - X|_{\overline{\mathcal{D}_j}}(x)$. If $y \in \mathcal{D}_i \cap R$ and $y' \in \mathcal{D}_j \cap R$ tend to x , we deduce that $\|y - y'\|_2 \rightarrow 0$ while, at the same time,

$$\begin{aligned} \|X(y) - X(y')\|_2 |\cos \alpha(y, y')| \\ \geq \|X(y) - X(y')\|_2 \cos \beta \longrightarrow \|X|_{\overline{\mathcal{D}_i}}(x) - X|_{\overline{\mathcal{D}_j}}(x)\|_2 \cos \beta > 0. \end{aligned}$$

Therefore, there does not exist $L \in (0, \infty)$ such that (S3) is satisfied for $y \in R \cap \mathcal{D}_i \cap B(x, \varepsilon)$ and $y' \in R \cap \mathcal{D}_j \cap B(x, \varepsilon)$. Thus, X is not essentially one-sided Lipschitz on any neighborhood of x , and the hypotheses of Proposition 4 do not hold.

Sidebar 10: Regular Functions

To introduce the notion of regular function, we need to first define the right directional derivative and the generalized right directional derivative. Given $f : \mathbb{R}^d \rightarrow \mathbb{R}$, the *right directional derivative* of f at x in the direction of $v \in \mathbb{R}^d$ is defined as

$$f'(x; v) = \lim_{h \rightarrow 0^+} \frac{f(x + hv) - f(x)}{h},$$

when this limit exists. On the other hand, the *generalized directional derivative* of f at x in the direction of $v \in \mathbb{R}^d$ is defined as

$$f^o(x; v) = \limsup_{\substack{y \rightarrow x \\ h \rightarrow 0^+}} \frac{f(y + hv) - f(y)}{h} = \lim_{\substack{\delta \rightarrow 0^+ \\ \varepsilon \rightarrow 0^+}} \sup_{\substack{y \in B(x, \delta) \\ h \in [0, \varepsilon]}} \frac{f(y + hv) - f(y)}{h}.$$

The advantage of the generalized directional derivative compared to the right directional derivative is that the limit always exists. When the right directional derivative exists, these quantities may be different. When they are equal, we call the function regular. More formally, a function $f : \mathbb{R}^d \rightarrow \mathbb{R}$ is *regular at* $x \in \mathbb{R}^d$ if, for all $v \in \mathbb{R}^d$, the right directional derivative of f at x in the direction of v exists, and $f'(x; v) = f^o(x; v)$. A function that is continuously differentiable at x is regular at x . Also, a convex function is regular (cf. [9, Proposition 2.3.6]).

The function $g : \mathbb{R} \rightarrow \mathbb{R}$, $g(x) = -|x|$, is not regular. Since g is continuously differentiable everywhere except for zero, it is regular on $\mathbb{R} \setminus \{0\}$. However, its directional derivatives

$$g'(0; v) = \begin{cases} -v, & v > 0, \\ v, & v < 0, \end{cases} \quad g^o(0; v) = \begin{cases} v, & v > 0, \\ -v, & v < 0, \end{cases}$$

do not coincide. Hence, g is not regular at 0.

Jorge Cortés (Department of Mechanical and Aerospace Engineering, University of California at San Diego, 9500 Gilman Dr, La Jolla, CA 92093, phone 1-858-822-7930, fax 1-858-822-3107, cortes@ucsd.edu) received the Licenciatura degree in mathematics from the Universidad de Zaragoza, Spain, in 1997, and his Ph.D. degree in engineering mathematics from the Universidad Carlos III de Madrid, Spain, in 2001. He held postdoctoral positions at the Systems, Signals, and Control Department of the University of Twente, and at the Coordinated Science Laboratory of the University of Illinois at Urbana-Champaign. From 2004 to 2007, he was an assistant professor with the Department of Applied Mathematics and Statistics, University of California, Santa Cruz. He is currently an assistant professor in the Department of Mechanical and Aerospace Engineering, University of California, San Diego. His research interests focus on mathematical control theory, distributed motion coordination for groups of autonomous agents, and geometric mechanics and geometric integration. He is the author of *Geometric, Control and Numerical Aspects of Nonholonomic Systems* (Springer Verlag, 2002), and the recipient of the 2006 Spanish Society of Applied Mathematics Young Researcher Prize. He is currently an associate editor for the *European Journal of Control*.