

Section 1.1

Solving systems of equations

Outline of Section 1.1

- Learn what it means to solve a system of linear equations
- Describe the solutions as points in \mathbb{R}^n
- Learn what it means for a system of linear equations to be inconsistent

Solving equations

Solving equations

What does it mean to solve an equation?

$$2x = 10$$

$$x + y = 1$$

$$x + y + z = 0$$

Find one solution to each. Can you find all of them?

A solution is a *list* of numbers (a.k.a. a *vector*). For example $(3, -4, 1)$.

Solving equations

What does it mean to solve a system of equations?

$$x + y = 2$$

$$y = 1$$

What about...

$$x + y + z = 3$$

$$x + y - z = 1$$

$$x - y + z = 1$$

Is $(1, 1, 1)$ a solution? Is $(2, 0, 1)$ a solution? What are all the solutions?

Soon, you will be able to see just by looking that there is exactly one solution.

\mathbb{R}^n

\mathbb{R}^n

\mathbb{R} = denotes the set of all real numbers

Geometrically, this is the *number line*.

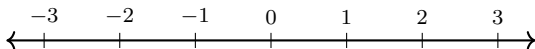

\mathbb{R}^n = all ordered n -tuples (or lists) of real numbers $(x_1, x_2, x_3, \dots, x_n)$

Solutions to systems of equations are exactly points in \mathbb{R}^n . In other words, \mathbb{R}^n is where our solutions will lie (the n depends on the system of equations).

We say \mathbb{R}^n instead of \mathbb{R}^2 or \mathbb{R}^3 because many of the things we learn this semester work just as well for \mathbb{R}^{777} as they do for \mathbb{R}^2 and \mathbb{R}^3 . So when we say \mathbb{R}^n we are talking about all of these at once. That is power!

\mathbb{R}^n

When $n = 2$, we can visualize of \mathbb{R}^2 as the *plane*.

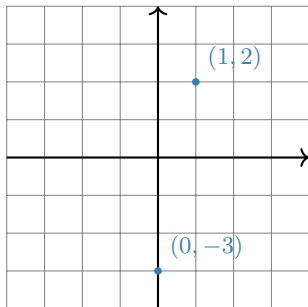

\mathbb{R}^n

When $n = 3$, we can visualize \mathbb{R}^3 as the *space* we (appear to) live in.

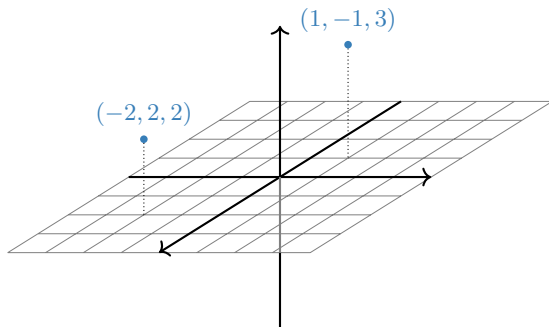

\mathbb{R}^n

We can think of the space of all *colors* as (a subset of) \mathbb{R}^3 :

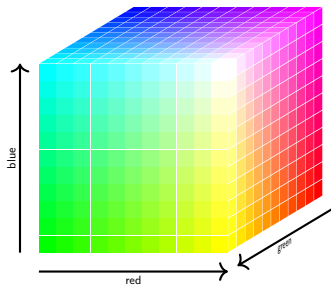

\mathbb{R}^n

So what is \mathbb{R}^4 ? or \mathbb{R}^5 ? or \mathbb{R}^n ?

...go back to the *definition*: ordered n -tuples of real numbers

$$(x_1, x_2, x_3, \dots, x_n).$$

They're still "geometric" spaces, in the sense that our intuition for \mathbb{R}^2 and \mathbb{R}^3 sometimes extends to \mathbb{R}^n , but they're harder to visualize.

Last time we could have used \mathbb{R}^3 to describe a rabbit population in a given year: (first year, second year, third year).

Similarly, we could have used \mathbb{R}^4 to label the amount of traffic (x, y, z, w) passing through four streets.

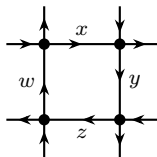

We'll make definitions and state theorems that apply to any \mathbb{R}^n , but we'll only draw pictures in \mathbb{R}^2 and \mathbb{R}^3 .

\mathbb{R}^n

and QR codes

This is a 21×21 QR code. We can also think of this as an element of \mathbb{R}^n .



How? Which n ?

What about a greyscale image?

This is a powerful idea: instead of thinking of a QR code as 441 pieces of information, we think of it as one piece of information.

Visualizing solutions: a preview

One Linear Equation

What does the solution set of a linear equation look like?

$x + y = 1 \rightsquigarrow$ a line in the plane: $y = 1 - x$

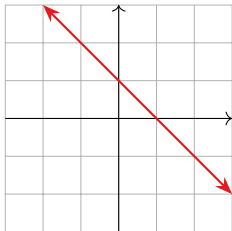

One Linear Equation

What does the solution set of a linear equation look like?

$x + y + z = 1$ \rightsquigarrow a plane in space:

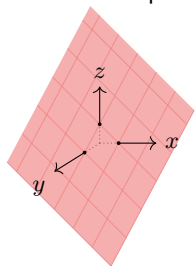

One Linear Equation

Continued

What does the solution set of a linear equation look like?

$x + y + z + w = 1$ \rightsquigarrow a “3-plane” in “4-space” ...

Systems of Linear Equations

What does the solution set of a *system* of more than one linear equation look like?

$$x - 3y = -3$$

$$2x + y = 8$$

What are the other possibilities for two equations with two variables?

What if there are more variables? More equations?

Poll

Is the plane $x + y + z = 1$ in \mathbb{R}^3 equal to \mathbb{R}^2 ? What about the xy -plane in \mathbb{R}^3 ?

1. yes + yes
2. yes + no
3. no + yes
4. no + no

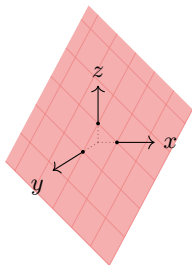

Consistent versus Inconsistent

We say that a system of linear equations is **consistent** if it has a solution and **inconsistent** otherwise.

$$x + y = 1$$

$$x + y = 2$$

Why is this inconsistent?

What are other examples of inconsistent systems of linear equations?

Parametric form

The equation $2x + 2y = 2$ is an **implicit equation** for the line in the picture.



It also has a **parametric form**: $(x, 1 - x)$.

The difference is that in the parametric form you get to plug in whatever you want for all variables. There's no guesswork, and no solving of anything.

Similarly the equation $x + y + z = 1$ is an implicit equation. One parametric form is: $(x, y, 1 - x - y)$.

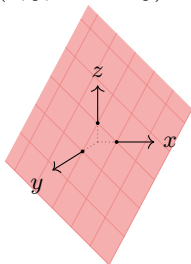

Parametric form

The equation $y = 1 - x$ is an **implicit equation** for the line in the picture.



It also has a **parametric form**: $(x, 1 - x)$.

The difference is that in the parametric form you get to plug in whatever you want for all variables. There's no guesswork, and no solving of anything.

Similarly the equation $x + y + z = 1$ is an implicit equation. One parametric form is: $(x, y, 1 - x - y)$.

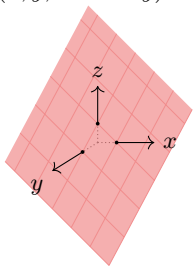

What is an implicit equation and a parametric form for the xy -plane in \mathbb{R}^3 ?

Parametric form

The system of equations

$$2x + y + 12z = 1$$

$$x + 2y + 9z = -1$$

is the **implicit form** for the line of intersection in the picture.

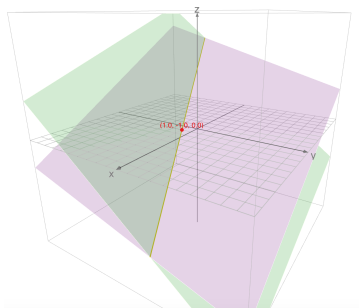

The line of intersection also has a **parametric form**: $(1 - 5z, -1 - 2z, z)$

We think of the former as being the problem and the latter as being the explicit solution. One of our first tasks this semester is to learn how to go from the implicit form to the parametric form.

Summary of Section 1.1

- A solution to a system of linear equations in n variables is a point in \mathbb{R}^n .
- The set of all solutions to a single equation in n variables is an $(n - 1)$ -dimensional plane in \mathbb{R}^n .
- The set of solutions to a system of m linear equations in n variables is the intersection of m of these $(n - 1)$ -dimensional planes in \mathbb{R}^n .
- A system of equations with no solutions is said to be inconsistent.
- Line and planes have implicit equations and parametric forms.

Typical exam questions

Write down an example of a point in \mathbb{R}^7 .

Find all values of h so that the following system of linear equations is consistent:

$$\begin{aligned}x + y + z &= 2 \\ 2x + 2y + 2z &= h\end{aligned}$$

True/False: Points in \mathbb{R}^3 are also points in \mathbb{R}^4 .

Find two different parametric solutions to the equation $x - 3y = 5$.

True/False: the set of solutions to $x_1 = 1$ in \mathbb{R}^5 is a line.